



| Residential Hybrid Inverters Advantages

| Clean Power for You

### ➤ Deye hybrid inverter advantages at a glance

- A full range of products 3.6/5/7.6/8KW with output voltage of 230V/208/240Vac; the DC/AC ratio of 1.3.
- More higher charging and discharging power of 120A &5000W. Max. instantaneous power is 10000W@10S.
- Independent Grid port, diesel generator port and backup load port, easy connection.
- Built-in DG control interface, and support DG charges the battery ensuing the system works within 7\*24H.
- Compatible with solar panel and wind turbine as well.
- 2 kinds of AC couple method to update existing solar system to energy storage system.
- Adopt V/f droop control, support Max. 16 units paralleled and three-phase application without additional accessory.
- “Time of use” function, support 6 different time periods for charging and discharging battery.
- 4ms fast transfer from on-grid to off-grid mode, ensuing the traditional fixed frequency air conditioner works well
- Colorful touch screen and buttons, easy operation and maintenance.
- Smart load application, expanding output interface
- Grid peak-shaving function, improving self-consumption ratio of solar energy
- 48V low voltage battery, built-in transformer for electrical isolation more security.

# 5KW Hybrid Inverter Features

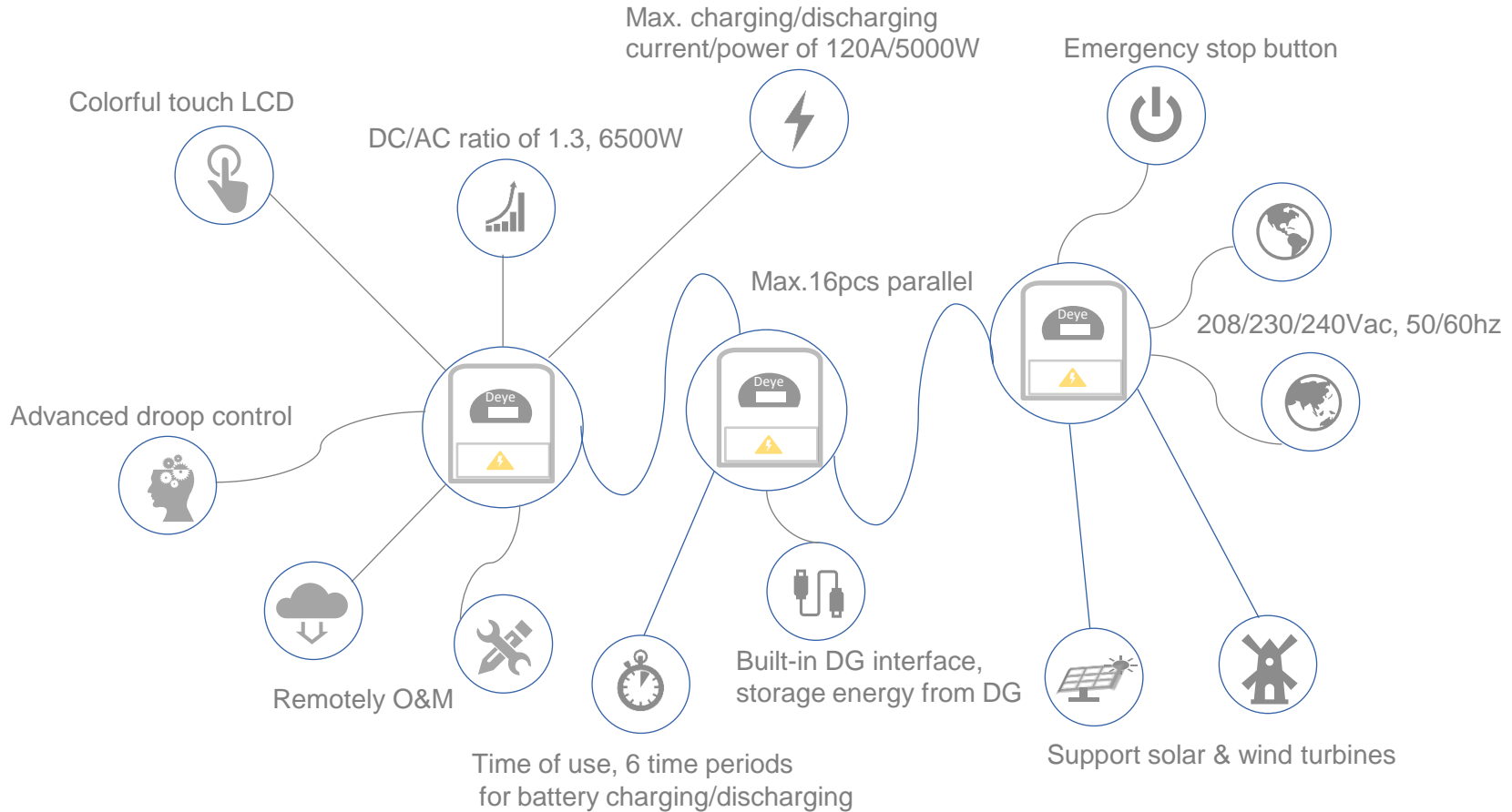

### DC/AC ratio up to 1.3, saving equipment investment

- Completely compatible with double-side solar panel, flexible choose different kinds PV modular
- Under some special conditions such as low irradiation, more solar panel connected will efficiently increase power generation.

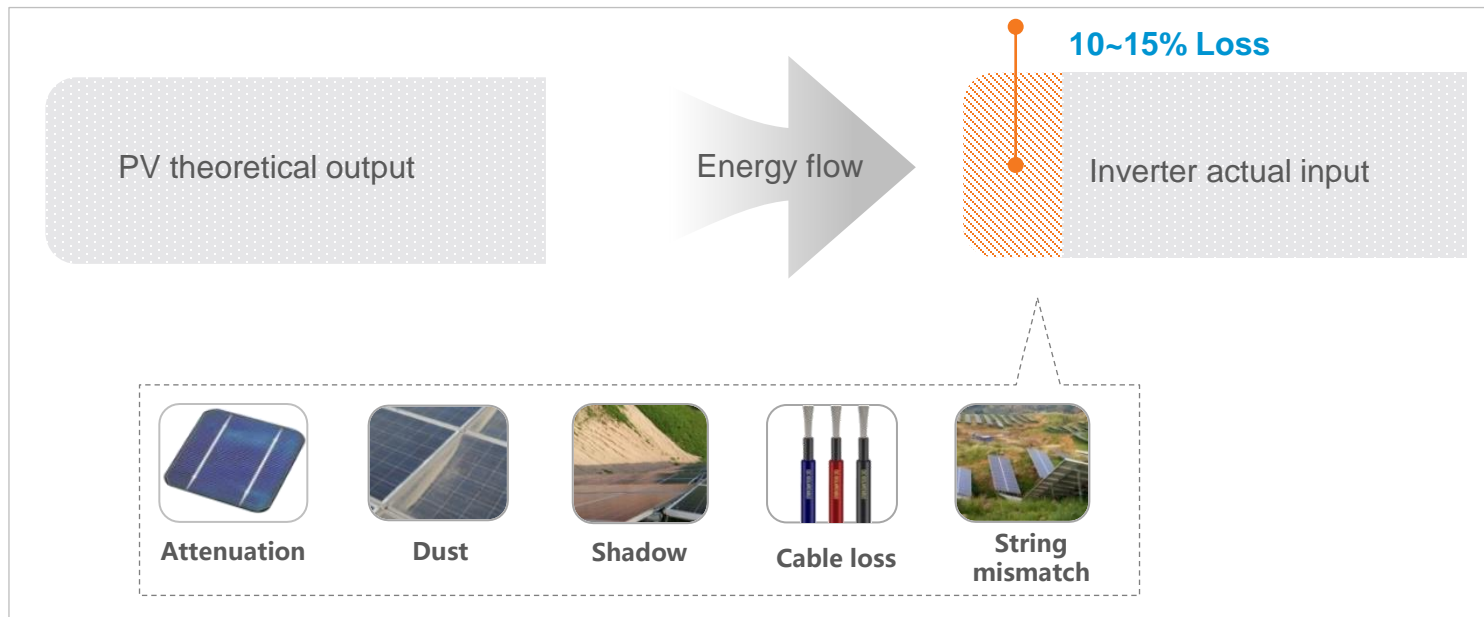

## Independent Backup Load Port

Deye 德業 / 1990-2020

- Integrating independent grid port, diesel generator port and load port, more flexible and powerful.
- The diesel generator port also can be used as input or output port. As AC input, it can connect microinverter or string inverter. When as output port, it can used to power the load (Smart load)
- Built-in ON/OFF switch, easily cuts off output when emergency situation, more safe and reliable.

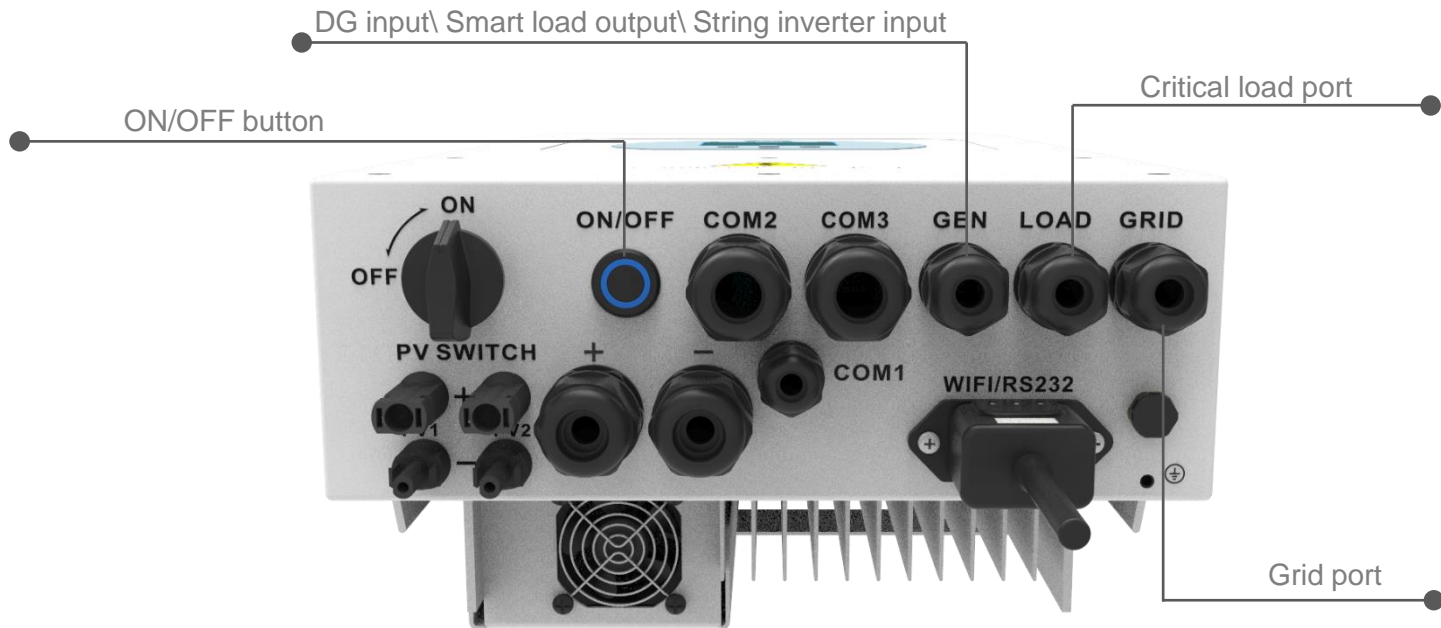

- The diesel generator port can be used as an output port. When as an output port, it can be used to power the load (smart load)

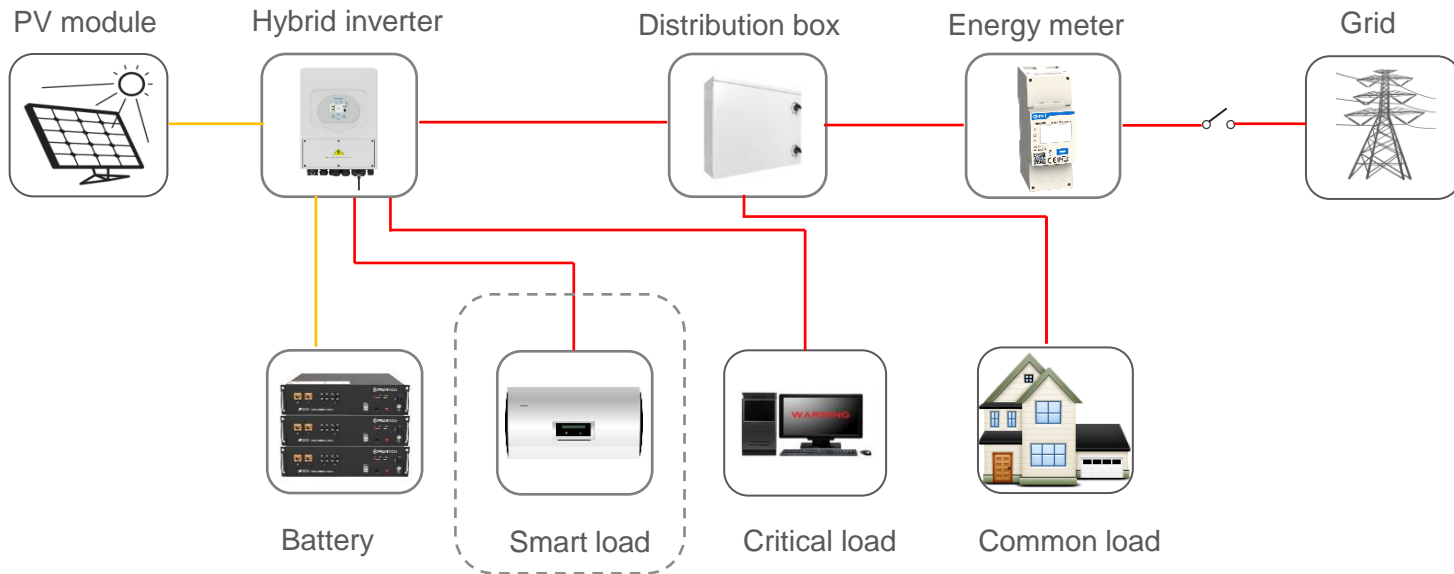

## Supports diesel generator charges battery

- When utility grid cuts off, the hybrid inverter is able to start DG to supply load and charge battery.

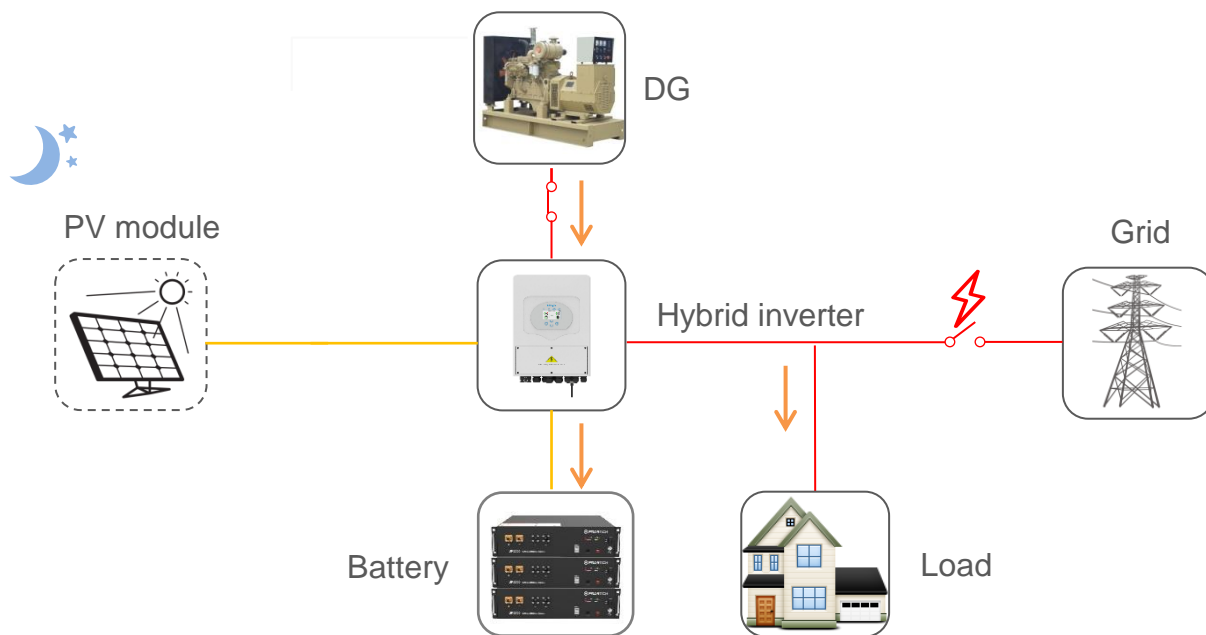

## Supports diesel generator charges battery

- When utility grid cuts off, the hybrid inverter is able to start DG to supply load and charge battery.

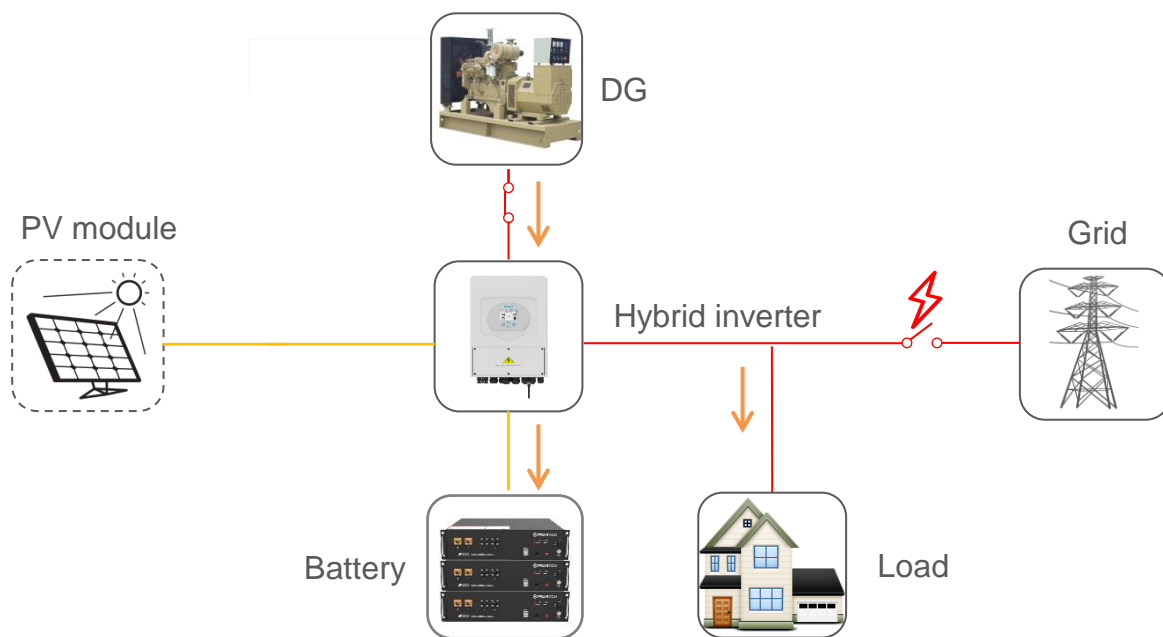



## Supports control diesel generator automatically

- Built-in DG control interface, the hybrid inverter is able to start or stop DG to supply load and charge battery.

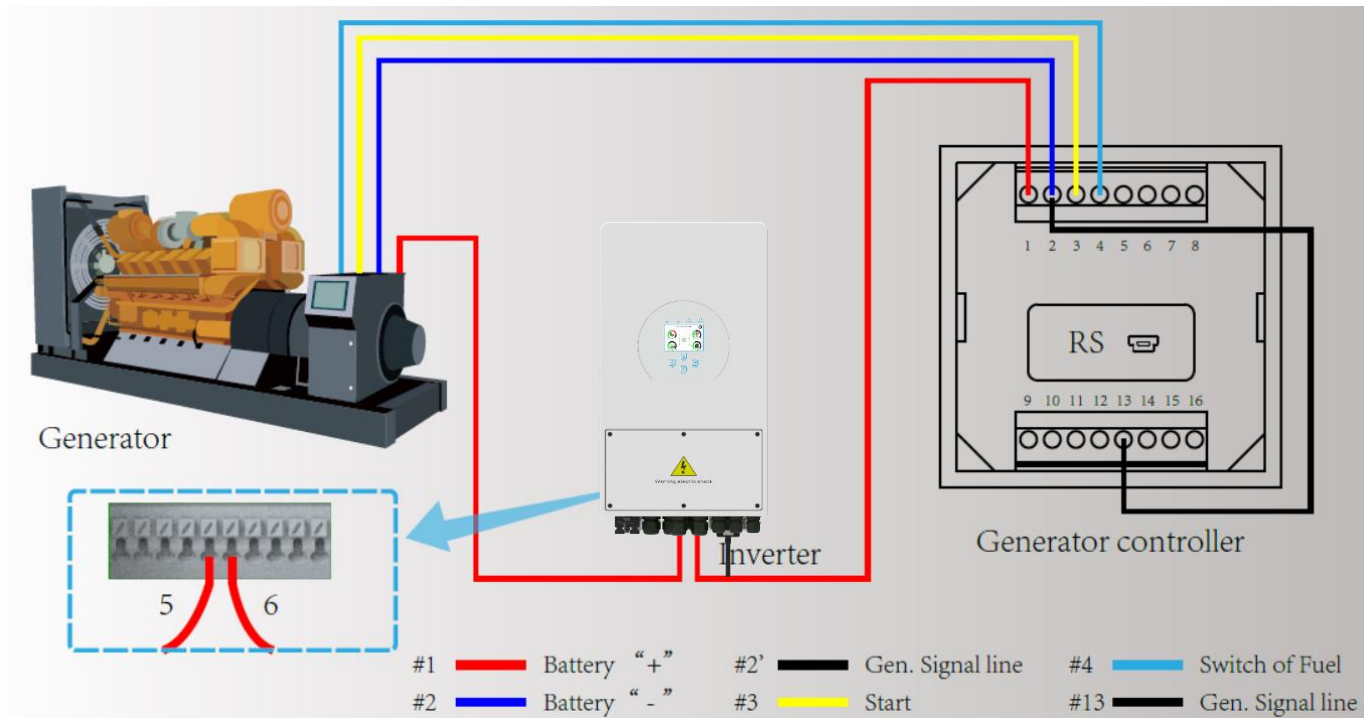

- “Time of use”, time-dependent electricity tariffs, customers pay different prices for their energy consumption at different times of the day. Below figure shows typical time-of-use tariffs applied in Australia.
- For this situation, Deye hybrid inverter allows users to set time windows for charging and discharging the energy storage system. In this way, the behavior of the hybrid inverter can be adjusted in line with the time-dependent electricity tariffs, reducing electricity bills.

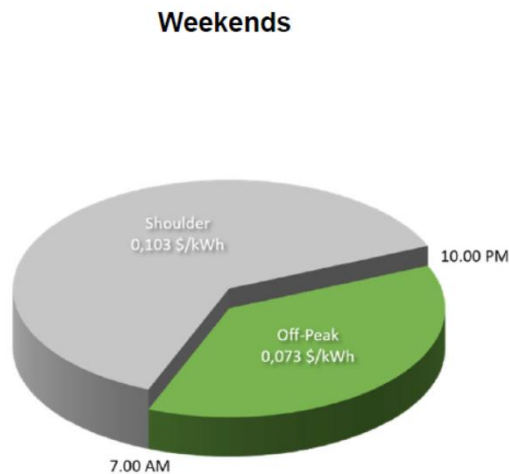
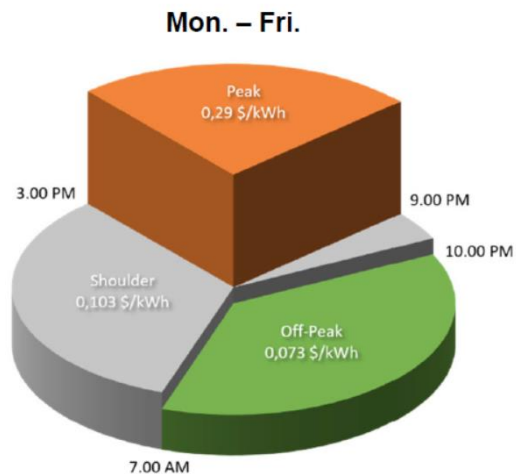

Time of use interface

**System Work Mode**

Grid Charge	Gen	Time	Batt
<input type="checkbox"/>	<input type="checkbox"/>	01:00 ~ 5:00	80%
<input type="checkbox"/>	<input type="checkbox"/>	05:00 ~ 9:00	80%
<input type="checkbox"/>	<input type="checkbox"/>	09:00 ~ 13:00	80%
<input type="checkbox"/>	<input type="checkbox"/>	13:00 ~ 17:00	80%
<input type="checkbox"/>	<input type="checkbox"/>	17:00 ~ 21:00	80%
<input type="checkbox"/>	<input type="checkbox"/>	21:00 ~ 01:00	80%

Time Of Use

Work Mode2

- Compatible with wind turbine as well. Also, it supports 1<sup>st</sup> MPPT connects PV module and the other MPPT connects wind turbines. For others, they can only use solar panel as DC input energy.
- In the off-grid mode, the peak output power is up to 10000W@10S

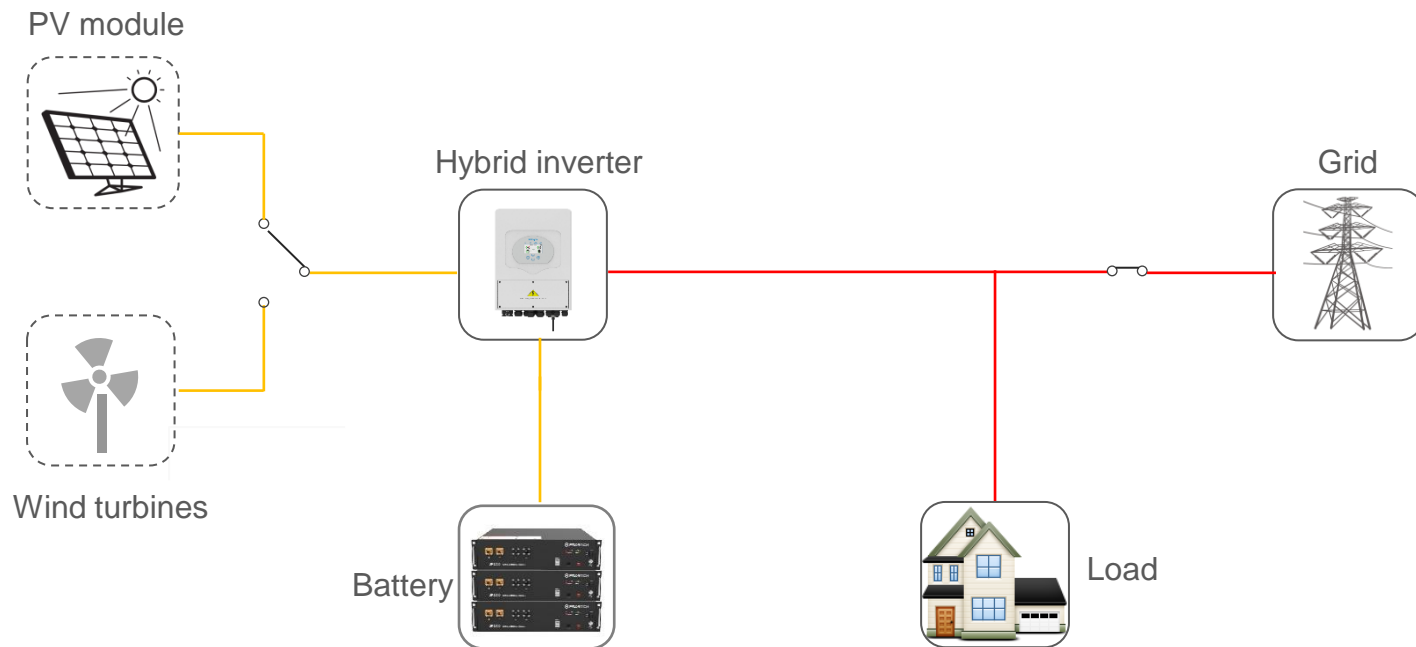

- Update the existing solar system to energy storage system, which is applicable to area with low FIT and high energy price, and the hybrid inverter working as battery charge controller in the system.
- In this mode, an external CT is needed to detect energy flow direction.

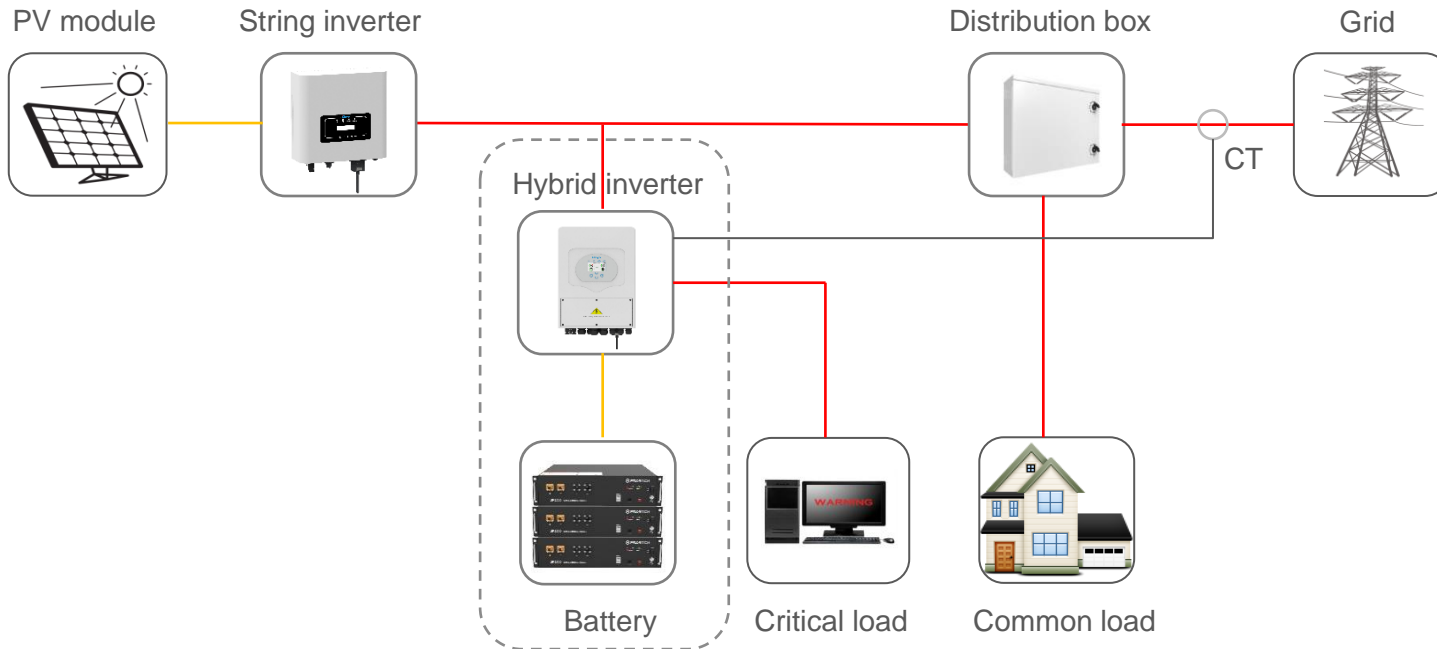

- Update the existing solar system to energy storage system. This solution is more flexible even during the grid is not present, the whole system is still able to run.
- System allows string inverter output energy to charge the battery or supply load.

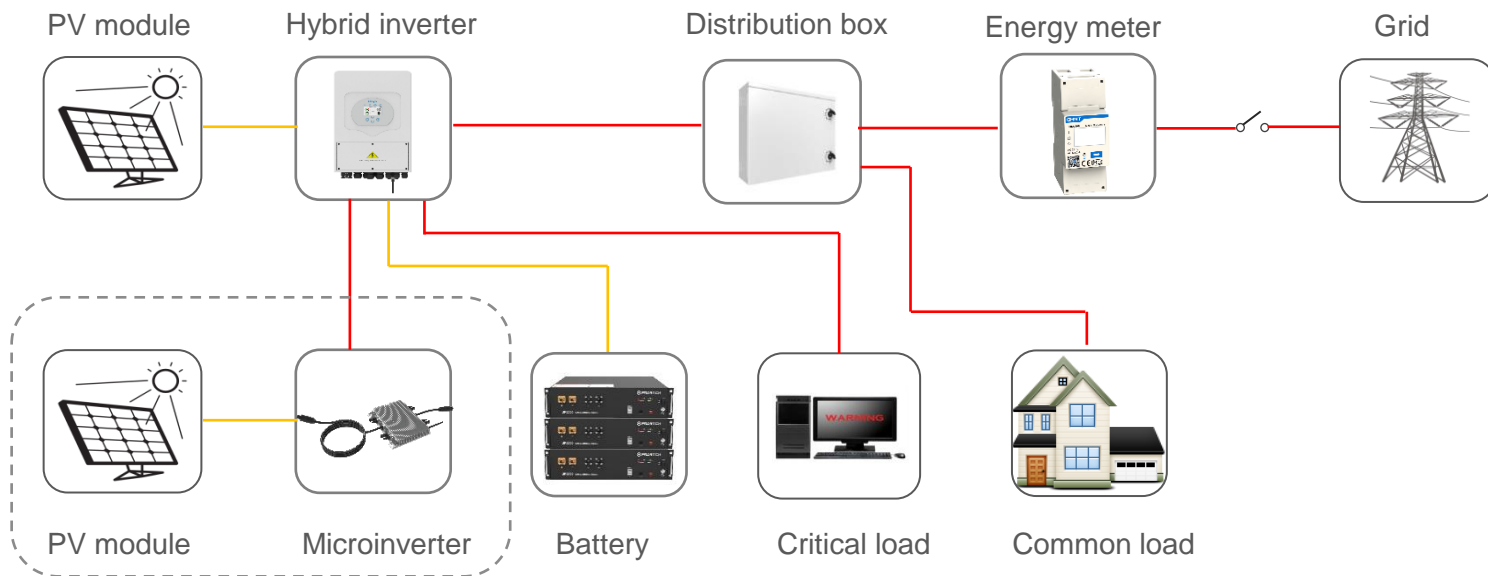

- In the above microgrid system (islanding mode), hybrid inverter adopts droop control to establish and regulate system V/f.
- At the same time, the string inverter works in PQ mode. If needed, the hybrid inverter is capable of disconnecting from the string inverter to keep system reliable.

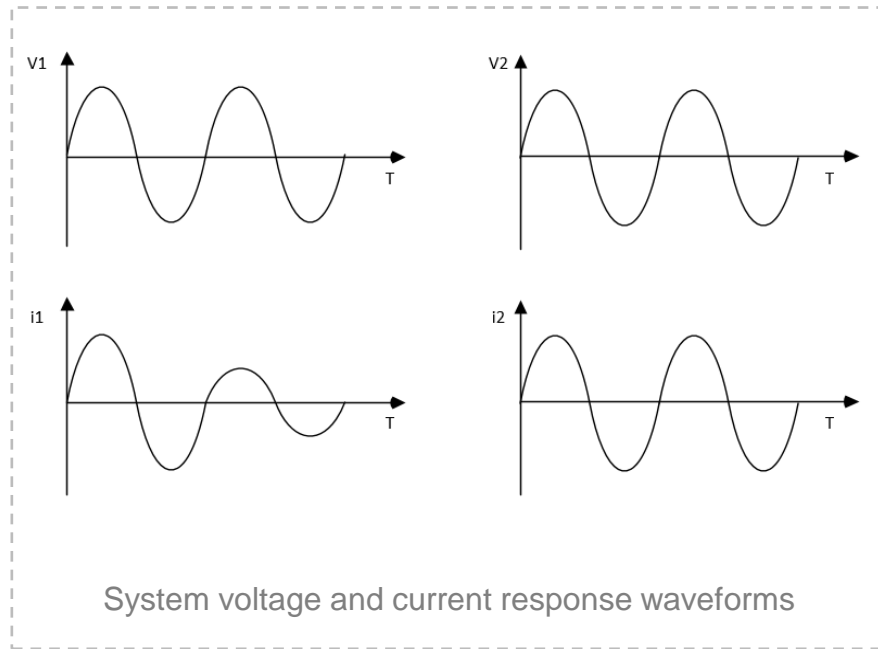
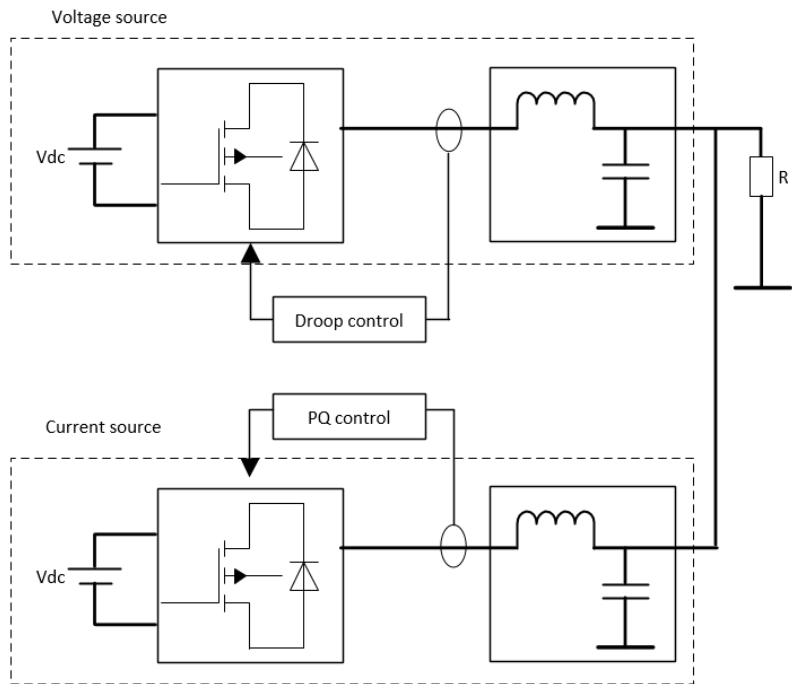

- In the parallel system, the master hybrid inverter measure and calculate  $U_{ref}/I_{ref}$  and send to slave inverters by communication cable.
- With this feature, it ensures each hybrid inverter has same output power in parallel system, and makes system more stable and reliable.

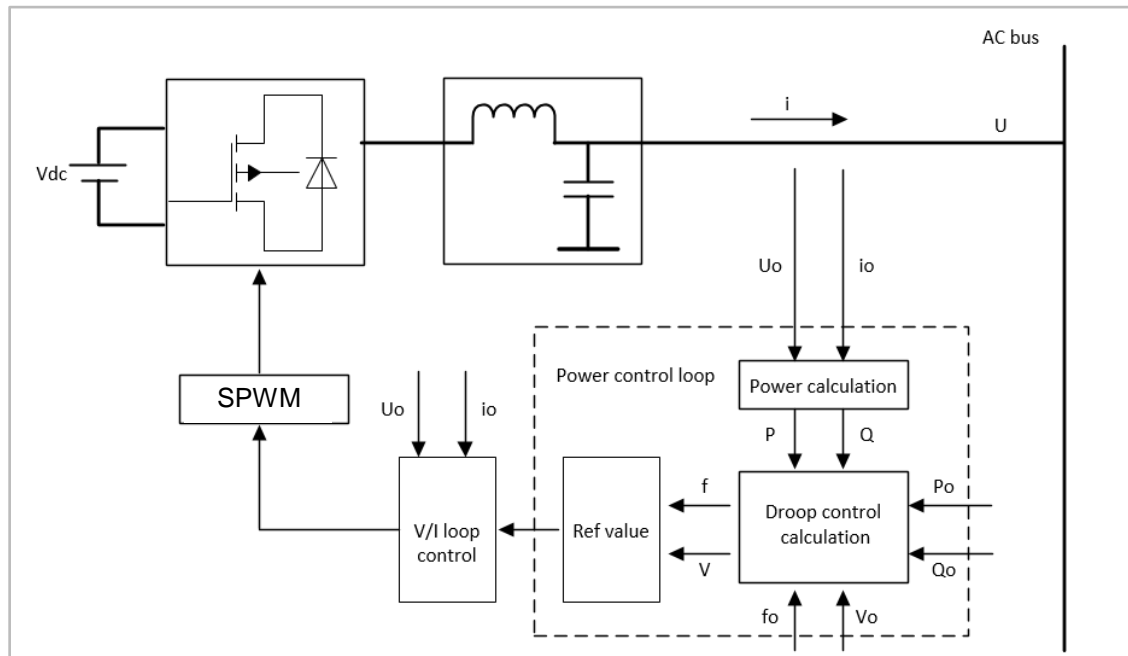
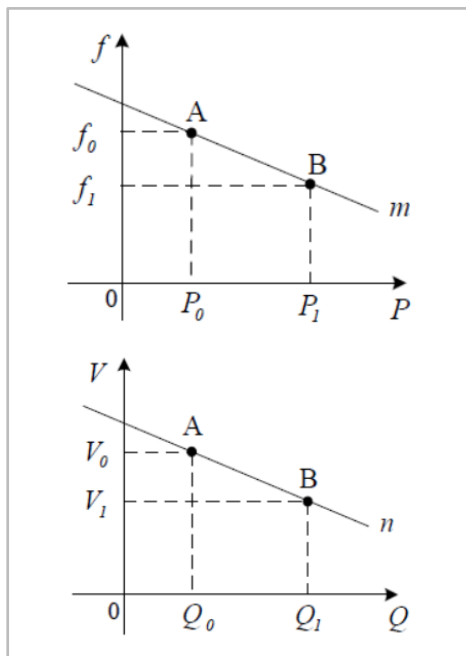

# Support Max. Number of Parallel of 16pcs

- Support Max. number of parallel of 16pcs

Single-phase system diagram

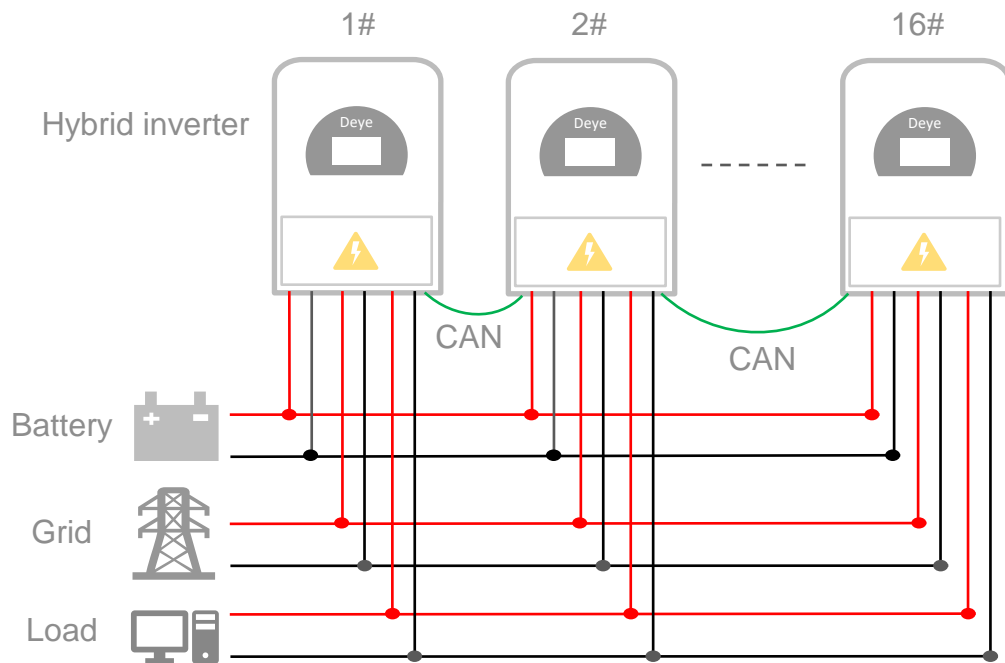



## ■ Three-phase system diagram

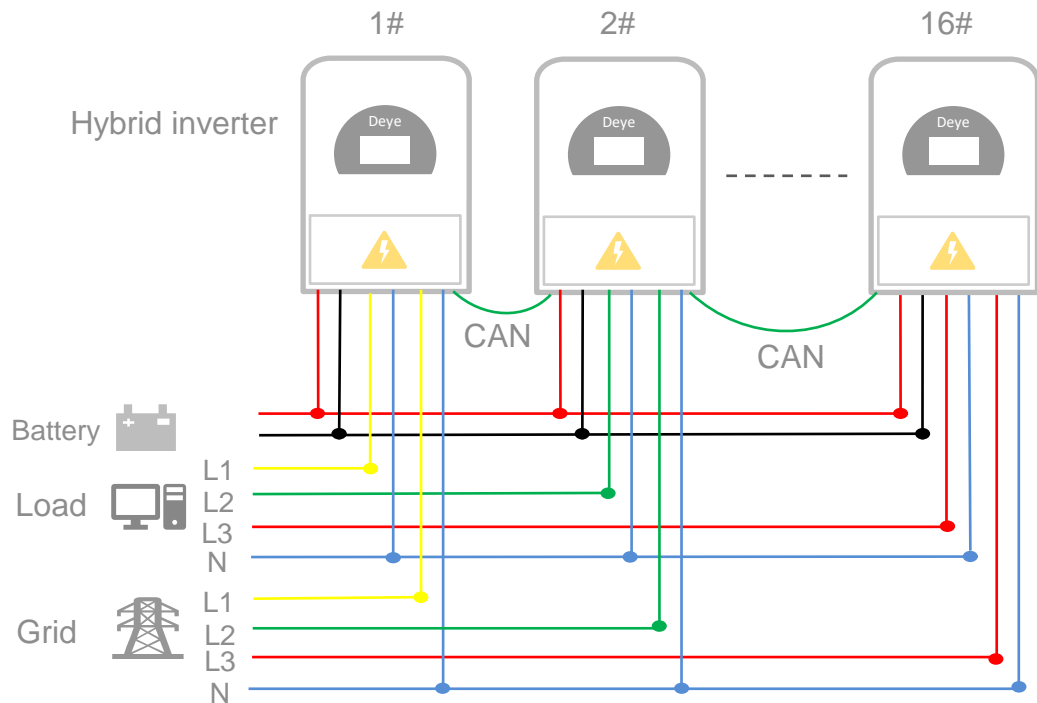

## ■ Support set parameters and FW update remotely

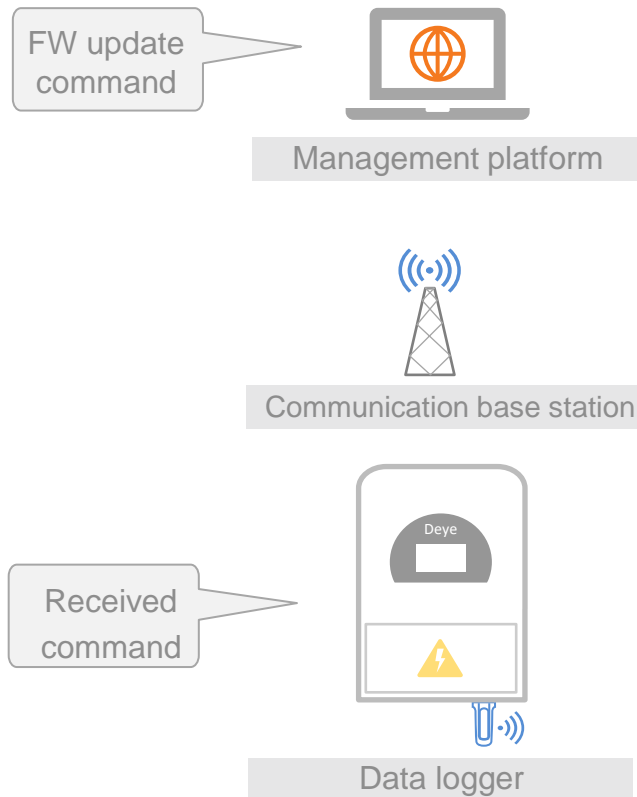

### Short time for FW update

- Remotely inverter parameter setting and software upgrade within 20 minutes



### Save time, save cost

- Not need O&M engineer on site to check and operation

- Check your solar station by your mobile phone and PC at any time and any where.
- For distributor and installer, they can find and fix problems before end user complaint

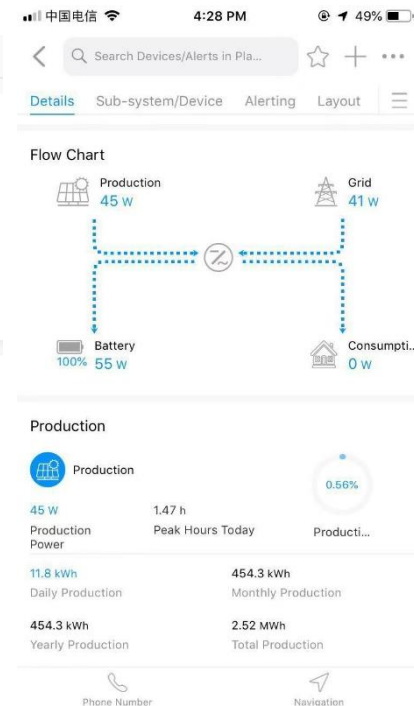
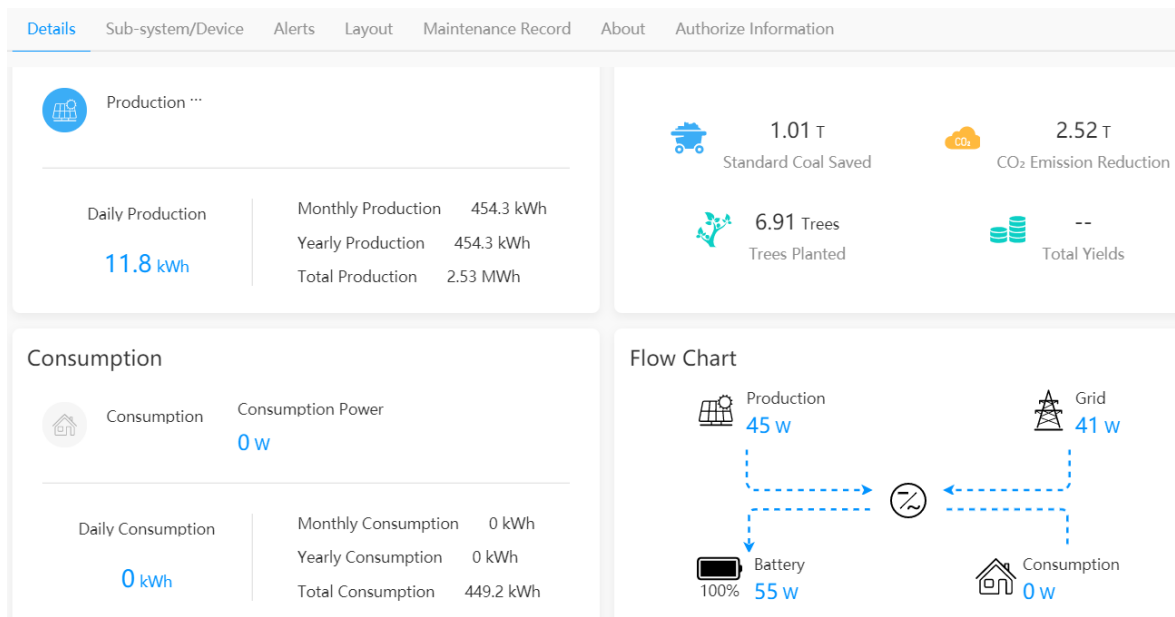

- Record fault codes with date, also check and set parameters remotely.

8KW solar energy s... ▼

Edit Tags

✔ Normal Communication ✔ No Alerts

2019/12/31 16:19:52 UTC+08:00

[Details](#) [Sub-system/Device](#) [Alerts](#) [Layout](#) [Maintenance Record](#) [About](#) [Authorize Information](#)

Total 1 Alert(s)

This Month ▼

Please enter alert name



Alert Name	Type	Plants	Device	Importance <span>↕</span>	Influence	Last Trigger Time <span>↕</span>
-- /ID 795	Protocol Alert	8KW solar energy storage plant	Inverter 1905044002	Warnings	Influence Prod...	18:01:49 2019/12/09 UTC+08:00

[Parameter Read&Write](#)

Customized Command

Last Command Record →

Command Name: Read Battery CV Charge Voltage Send time: 2019/12/24 18:54:31 UTC+08:00

Command State: ✔ Succeeded

Feedback Time: 2019/12/24 18:54:36 UTC+08:00 Read Result: 57.6 V

Select Command

Command Name: Please Select ▼

- Read ON-OFF Enable
- Set ON-OFF Enable
- Read Restore Factory Settings
- Set Restore Factory Settings

Timeout:  Minute ?[Send Command](#)

- **Local colorful touch LCD screen** with buttons, more reassurance after seeing the data
- Graphic shows the system energy flow direction real-time, easy understand.

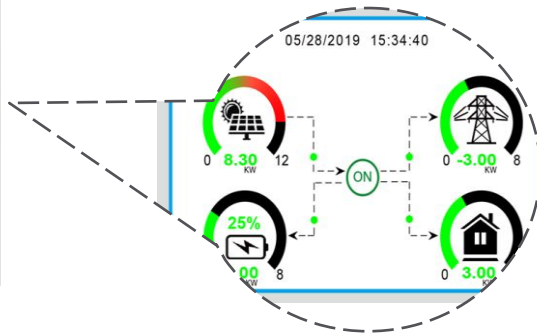

PV Status



Grid Status



Battery Status



Load Status

- Full series IP65 protection degree, sufficient heat dissipation, adapt to harsh environment, high reliability.

External fully enclosed glue-filled inductor, greatly inducing heat and noise from inductor

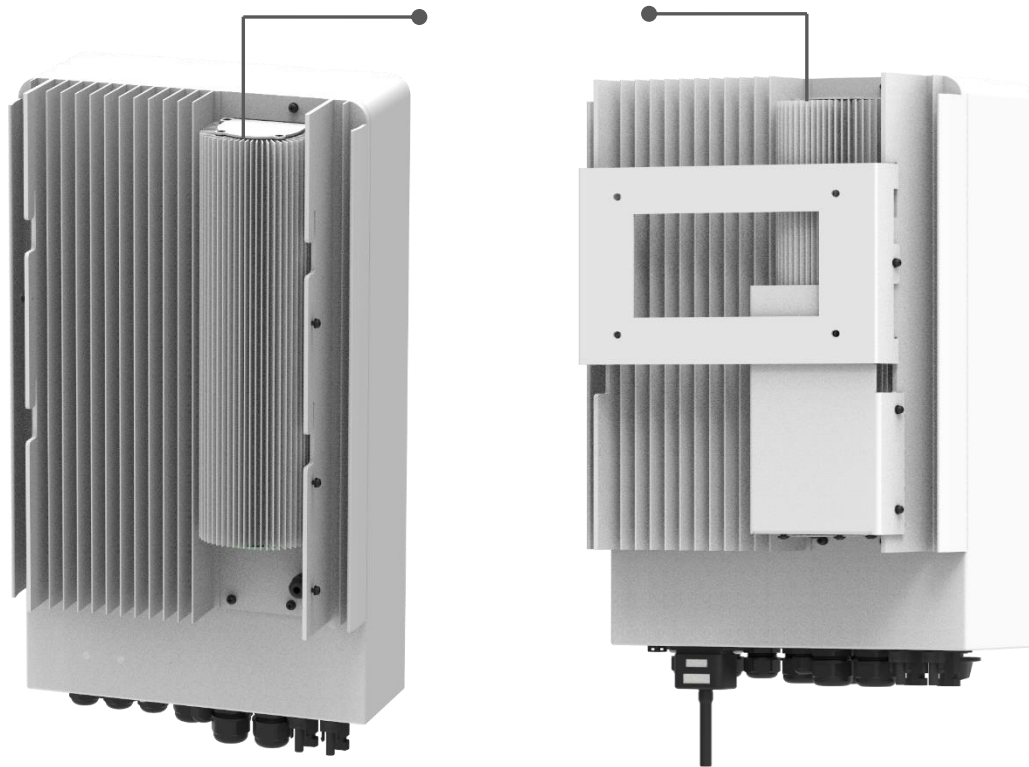

**Zero-export output**—intelligent adjust output power, meeting different requirements.

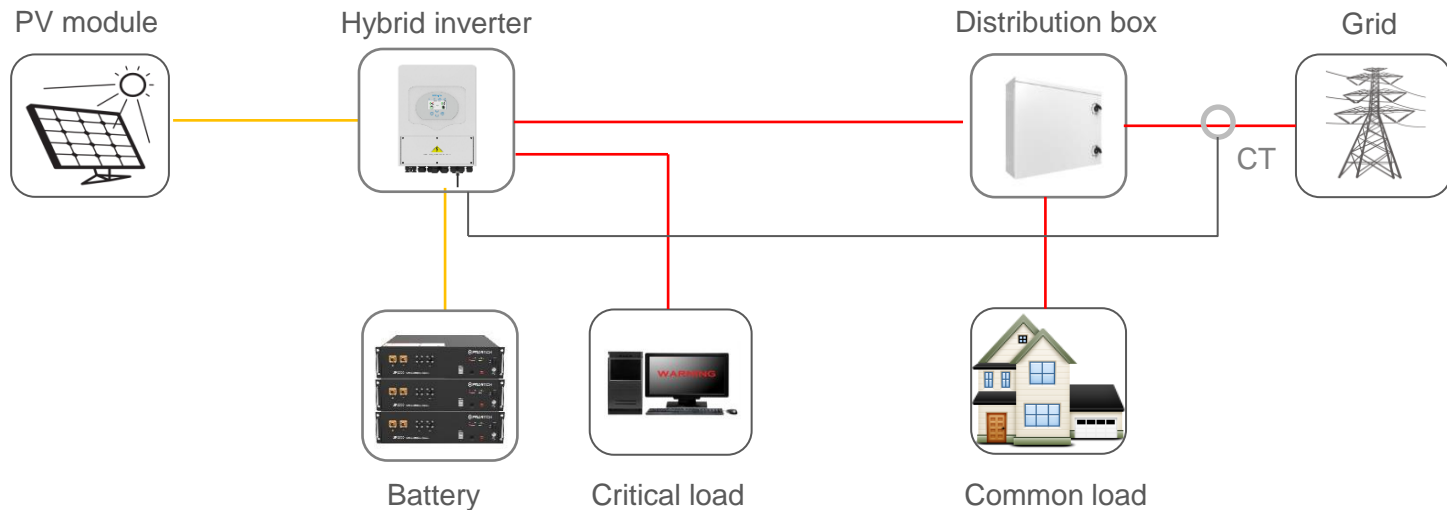

THANK YOU !