



K A C O 
new energy.

blueplanet
50.0 TL3 Basic/M/XL

Operating Instructions

- **English translation of
German original**

These instructions form part of the product and must be observed. They must also be stored in a place which is freely accessible at all times.

Operating Instructions

Contents

1	General information	4	7.7	AC and DC overvoltage protection upgrade	25
1.1	About this document.....	4	7.8	Connecting the interfaces.....	26
1.2	Layout of Instructions.....	4	7.9	Sealing the connection area	30
1.3	Target group.....	5	7.10	Switching on the device	30
2	Safety	5	8	Configuration and Operation	31
2.1	Proper use	6	8.1	Controls.....	31
2.2	Protection features	6	8.2	Initial start-up	34
2.3	Identification.....	6	8.3	Menu structure.....	34
2.4	More information	7	8.4	Inverter monitoring.....	46
3	Description	7	8.5	Performing the software update	48
3.1	Mode of Operation	7	9	Maintenance/Troubleshooting	49
3.2	Diagram	7	9.1	Visual inspection.....	49
4	Technical Data	10	9.2	Cleaning the housing	49
4.1	Electrical data	10	9.3	Replacing or cleaning the fans.....	50
4.2	Mechanical data.....	11	9.4	Servicing the heat sinks	50
4.3	Environmental conditions	11	9.5	Shutting down for maintenance and troubleshooting.....	51
5	Transportation and Delivery	12	9.6	Disconnecting connections.....	52
5.1	Scope of delivery.....	12	9.7	Faults.....	53
5.2	Transportation.....	12	9.8	“Fault” messages on the display/LED	55
6	Mounting	13	10	Service	60
6.1	Unpacking.....	14	11	Shutdown/Disassembly	61
6.2	Installing the wall bracket.....	15	11.1	Switching off the unit	61
6.3	Installing the unit	16	11.2	Uninstalling the device	61
7	Electrical connection	17	11.3	Disassembling the unit	62
7.1	Switching off the unit	17	11.4	Packaging the unit.....	62
7.2	Preparing the AC connection.....	18	11.5	Storing the unit.....	62
7.3	Connection to the power grid	19	12	Disposal	62
7.4	Preparing the DC connection	22	13	Appendix	63
7.5	Connecting the PV generator	24	13.1	EU Declaration of Conformity.....	63
7.6	Grounding the housing	25			

1 General information

1.1 About this document



WARNING

Improper handling of the device can be hazardous!

- › You must read and understand the operating instructions so that you can install and use the device safely!

1.1.1 Other applicable documents

During installation, observe all assembly and installation instructions for components and other parts of the system. These instructions also apply to the equipment, related components and other parts of the system. Some of the documents which are required for the registration and approval of your photovoltaic (PV) system are included with the operating instructions.

1.1.2 Storing the documents

These instructions and other documents must be stored near the system and be available at all times. The content of these instructions is revised on a regular basis and updated if necessary. You can download the current version of the operating instructions at www.kaco-newenergy.com.

1.1.3 English translation of German original

These operating instructions have been produced in several languages. The German-language version of the operating instructions is the original version. All other language versions are translations of the original operating instructions.

1.2 Layout of Instructions

1.2.1 Symbols used



General hazard



Risk of fire or explosion!



High voltage!



Risk of burns

Authorized electrician

Only authorised electricians are permitted to carry out tasks indicated with this symbol!

1.2.2 Safety warnings symbols guide



DANGER

High risk

Failure to observe this warning will lead directly to serious bodily injury or death.



WARNING

Potential risk

Failure to observe this warning may lead to serious bodily injury or death.



CAUTION

Low-risk hazard

Failure to observe this warning will lead to minor or moderate bodily injury.

CAUTION
Risk of damage to property

Failure to observe this warning will lead to property damage.

EN

1.2.3 Additional information symbols

NOTE

Useful information and notes

EN
Country-specific function

Functions restricted to one or more countries are labelled with country codes in accordance with ISO 3166-1.

1.2.4 Instructions symbols guide

Instructions

⌚ Prerequisite(s) before carrying out the following step(s) (optional)

1. Carry out step.

2. (Additional steps, if applicable)

» Result of the step(s) (optional)

1.3 Target group

All activities described in the document may only be carried out by specially trained personnel with the following qualifications:

- Knowledge about how an inverter functions and operates
- Training in the handling of hazards and risks during the installation and operation of electrical devices and systems
- Education concerning the installation and start-up of electrical units and systems
- Knowledge of applicable standards and directives
- Knowledge and adherence to this document with all safety notices.

2 Safety

DANGER

Lethal voltages are still present in the terminals and cables of the inverter even after the inverter has been switched off and disconnected!

Severe injuries or death will occur when touching the cables and terminals in the inverter.

- › Only appropriately qualified and authorised electricians may open, install or maintain the inverter.
- › Keep the inverter closed when the unit is in operation.
- › Do not touch the cables or terminals when switching the unit on and off.
- › Do not make any modifications to the inverter.

The electrician is responsible for observing all existing standards and regulations.

- Be sure to observe IEC 60364-7-712:2002 "Requirements for special installations or locations – solar photovoltaic (PV) power supply systems" in particular and all applicable regulations and specifications.
- Ensure operational safety by providing proper grounding, conductor dimensioning and appropriate protection against short circuiting.
- Observe all safety instructions on the inverter and in these operating instructions.

- Switch off all voltage sources and secure them against being inadvertently switched back on before performing visual inspections and maintenance.
- When taking measurements while the inverter is live:
 - Do not touch the electrical connections
 - Remove all jewellery from wrists and fingers.
 - Ensure that the testing equipment is in safe operating condition.
- Modifications to the surroundings of the inverter must comply with the applicable national and local standards.
- When working on the PV generator, it is also necessary to switch off the DC voltage with the DC isolator switch in addition to disconnecting the PV generator from the grid.

2.1 Proper use

The inverter converts the DC voltage generated by the PV modules into AC voltage and feeds it into the grid. The inverter is built according to the latest technological standards and safety regulations. Nevertheless, improper use may cause lethal hazards for the operator or third parties, or may result in damage to the device and other property.

Operate the inverter only with a permanent connection to the public power grid.

Any other or additional use is not considered proper or intended use and can lead to an annulment of the product guarantee. This includes:

- Mobile use
- Use in rooms where there is a risk of explosion
- Use of the inverter in direct sunlight, rain or a storm or other harsh environmental conditions
- Use in an outdoor area that does not meet the environmental conditions set down in the Technical Data, section 4.3
- Operation outside the specifications intended by the manufacturer
- Overvoltage of over 1100V on the DC connection.
- Modifying the unit
- Standalone mode

2.2 Protection features

The following monitoring and protection functions are built-in:

- Overvoltage conductors/varistors to protect the power semiconductors from high-energy transients on the grid and generator side
- Temperature monitoring of the heat sink / temperature monitoring of the interior
- EMC filters to protect the inverter from high-frequency grid interference
- Grid-side grounded varistors to protect the inverter against burst and surge pulses
- Standalone grid detection according to the current standards.

2.3 Identification

Identifying the unit

○ You will find the name plate with product-specific data for service and other requirements specific to installation on the right side panel of the inverter. This data includes:

- Product name
- Part no.
- Serial no.
- Date of manufacture
- Technical Data
- Disposal information
- Certification marking, CE marking.

KACO 		KACO blueplanet 50.0 TL3 M1 WM OD IIGX	
KACO new energy Carl-Zeiss-Strasse 1 74122 Heidenheim Made in Germany		Part number	1001430
		Serial number	50.0TL01654321
		Year	Q1 / 16
			
Input	V _{max} PV / I _{sc} PV (max) / I _{nom} PV	1100 V / 150 A / 90 A	
	V _{MPP} at P _{nom} / V ₋ range	580 V - 900 V	
Output	Nominal voltage	220 V	
		230 V	
		240 V	
Output Power	Voltage range continuous operation	3 x 176 V - 276 V (P-N)	
	Current (maximum continuous)	3 x 75.8 A	
	Frequency range	42 Hz - 68 Hz	
	S _{nom} at 220 V Unom	50 000 VA	
Output Power	S _{nom} at 230 V Unom	50 000 VA	
	S _{nom} at 240 V Unom	50 000 VA	
Environment	Reactive power cos phi	0-100% S _{nom} L-0.3 ind/cap	
	Temperature range	-20°C ... + 60°C	
	Protection class / Ingress protection	I / IP65	
ARC fault circuit protection			
Interface protection according to country specific requirements, details see manual		 	
No galvanic separation			

Figure 1: Type plate XL version

2.4 More information



NOTE

The EU Declaration of Conformity can be found in the appendix.

For information on grid coupling, grid protection and safety parameters along with more detailed instructions see our web site at <http://www.kaco-newenergy.de/>.

3 Description

3.1 Mode of Operation

The inverter converts the DC voltage generated by the PV modules into AC voltage and feeds it into the grid. The starting procedure begins when there is sufficient sunlight and a specific minimum voltage is present in the inverter. The feed-in process begins once the PV generator has passed the insulation test and the grid parameters are within the requirements imposed by the grid operator for a specific monitoring time. If, as it gets dark, the voltage drops below the minimum voltage value, feed-in operation ends and the inverter switches off.

3.2 Diagram

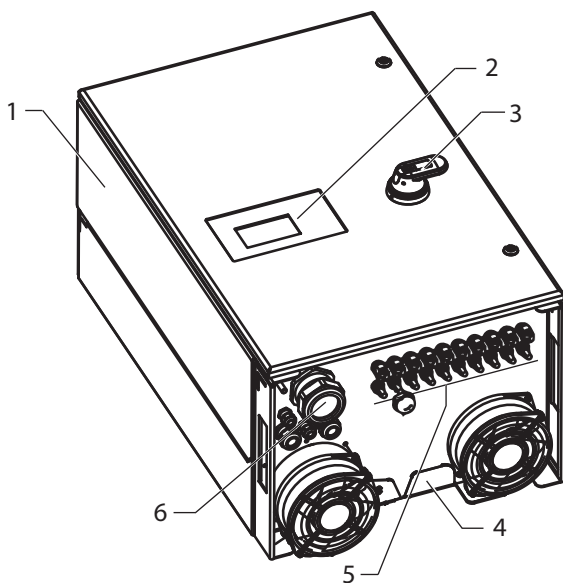

Figure 2: Inverter diagram - XL version

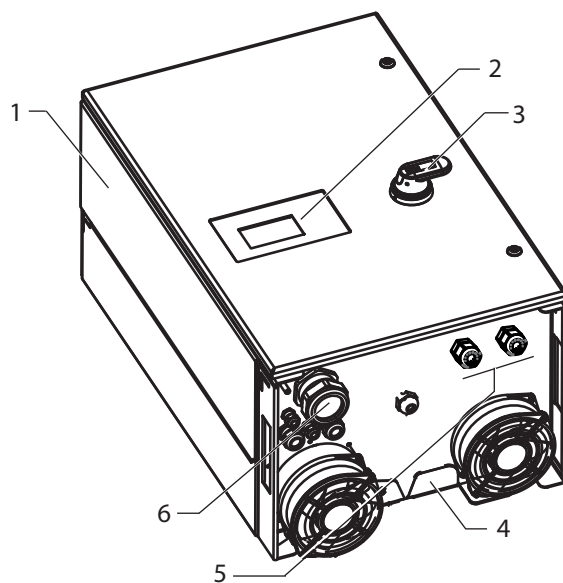

Figure 3: Inverter diagram - M version

Key

1	Housing	4	Wall bracket
2	Door with control panel	5	DC connection / fitting (M version)
3	DC isolator switch	6	Cable feed-through for AC connection

3.2.1 Mechanical components

DC isolator switch

The DC isolator switch is located on the front of the inverter housing. The DC isolator switch is used to disconnect the inverter from the PV generator in order to carry out service activities.

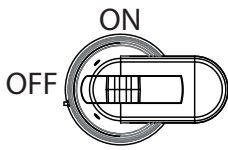

Figure 4: DC isolator switch

Disconnecting the inverter from the PV generator

- ☞ Switch the DC isolator switch from 1 (ON) to 0 (OFF).

Connecting the inverter to the PV generator

- ☞ Switch the DC isolator switch from 0 (OFF) to 1 (ON).

3.2.2 Electrical functions

A potential-free relay contact is integrated in the inverter. Use this contact for one of the following functions:

Fault signal relay

The potential-free relay contact closes as soon as there is a fault during operation. You use this function, for example, to signal a fault visually or acoustically.

Priwatt

The energy that is provided by the PV system can be put to use directly by the appliances that are connected in your home.

The potential-free contact can switch larger appliances (e.g. air conditioning units) on and off with the “priwatt” function activated. This requires an external power supply and an external load relay.

When the function is active, either the remaining runtime (in hours and minutes) or the shutdown threshold (in kW) is displayed on the start screen depending on the operating mode selected. The “priwatt” function is not active in the factory default setting. The option can be configured in the Settings menu.

3.2.3 Interfaces

You configure the interfaces and the web server in the Settings menu.

The inverter has the following interfaces for communication and remote monitoring:

Ethernet interface

Monitoring can occur directly on the unit using the integrated Ethernet interface. A local web server is installed in the unit for this purpose.

For the monitoring of a system consisting of multiple inverters, we recommend the utilization of the Powador-web portal on our homepage.

RS485 interface

In addition to the monitoring via the Ethernet interface, the monitoring can be executed via the RS485 interface.

USB interface

The USB connection of the inverter is a type A socket. It is located on the connection board in the door. The USB connection is specified to draw 100 mA of power. Use the USB interface to read out stored operating data and to load software updates using a FAT32-formatted USB stick.

“Inverter Off” input

If Powador protect is installed as a central grid and system protection, the fail-safe disconnection of suitable Powador or blueplanet inverters from the public grid can be initiated by a digital signal instead of external interface switches. This requires the inverters in the photovoltaic system to be connected to the Powador-protect.

If a Powador-protect is used for fast shutdown, it must be used as grid protection. The RS485 interface is not required for this.

For information on the installation and use see this manual, the Powador protect operating instructions and the instructions for use of the Powador protect on the KACO new energy website.

3.2.4 Inverter as part of a PV system

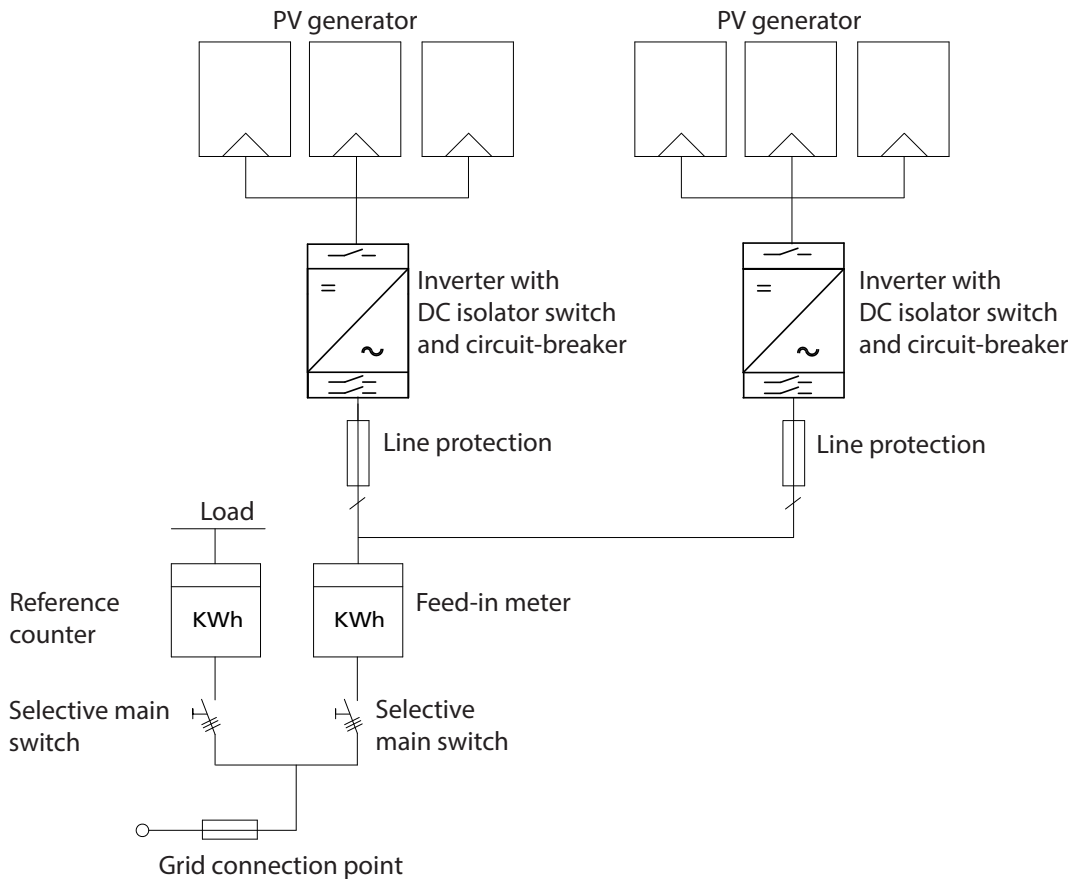

Figure 5: Circuit diagram of a system with two inverters

Key	Definition / Information about the connection
PV generator	The PV generator, i.e. the PV modules, converts the radiant energy of sunlight into electrical energy.
Inverter with: - DC connection	The PV generator is connected directly to the inverter's DC connection. Up to 10 strings can be connected to the DC connection in the XL device version.
- DC isolator switch	Use the DC isolator switch to disconnect the inverter from the PV generator.



DANGER



Lethal voltages are still present in the terminals and cables of the inverter even after the inverter has been switched off and disconnected!

Disconnect the DC side depending on the device version:

1. XL device version: Switch off the DC supply using the DC isolator switch.
Device version Basic and M: Switch off DC power supply externally via the combiner box (not supplied) and using the DC isolator switch.
2. Check that there is no current in any of the DC cables using a clip-on ammeter.
3. Only open the fuse holder once you have established that there is no current in the DC cables.
4. XL device version: Disconnect all DC connections one by one.
Device version Basic and M: Detach DC connection in the device (see section 9.6.1 on page 52).

Circuit breaker	A circuit breaker is an overcurrent protection device.
Feed-in meter	The feed-in meter is to be specified and installed by the power supply company. Some power supply companies also allow the installation of your own calibrated meters.
Selective main switch	The selective main switch is to be specified by the power supply company.

4 Technical Data

4.1 Electrical data

Input levels	
Recommended power range of the generator [kW]	50 - 70
MPP@Pnom from [V] to [V]*	580 @230/400V; 560 @220/380V; 610 @240/415V
Operating range from [V] to [V]	580 *... 1,050
Nominal voltage/ Starting voltage [V]	600 / 670
No-load voltage ($U_{OC\ max}$) [V]	1,100
Max. input current [A]	90
Max. power of the MPP tracker [W]	51,600
Number of DC connections	1 (Basic/M version) / 10 (XL version)
Number of MPP controls	1
max. short-circuit current ($I_{SC\ max}$) [A]	190
max. input source feedback current [A]	0
Polarity safeguard	no
Output levels	
Rated power [VA]	50,000
Grid voltage [V]	230/400 (3 / N / PE or 3 / PEN); 220/380; 240/415 (3 / N / PE or 3 / PEN)
Voltage range [V]	176 -276 (Ph-N) / 305-480 (Ph-Ph)
Rated current [A]	3x 72.4 @400 V; 3x 75.8 @380 V; 3x 69.5 @415 V
Max. continuous current [A]	75.8
Contribution to peak short-circuit current (ip) [A]	136.11
Initial short-circuit alternating current (Ik" first single period effective value) [A]	77.93
Start-up current [A]	1.21
Nominal frequency / frequency range [Hz]	50/60 / 42 - 68
cos phi	0.30 inductive ... 0.30 capacitive
Number of feed-in phases	3
Distortion factor (THD) [%]	< 1.6
General electrical data	
Max. efficiency [%]	98.5
European efficiency [%]	98.1
Power consumption: standby [W]	2.5
Feed-in starts at [W]	120
Circuit design	Transformerless
Grid monitoring	Country-specific

Table 1: Electrical data

4.2 Mechanical data

Display	Graphical LCD, 3 LEDs
Controls	4-way button, 2 buttons
Interfaces	2x Ethernet, USB, RS485 optional via additional module: 4-DI
Fault signal relay	Potential-free NO contact, max. 30 V/1 A DC
AC connection (version, type, feed-through cross section, cable cross section)	Basic, M and XL; connection via screw terminals, 95 mm ² , cable connection via cable fitting M63
DC connection (version, type, feed-through cross section, cable cross section)	Basic, M: Connection with cable lug, 95 mm ² , cable connection via cable fitting M32 XL: Connection via 10x DC plug connectors, 2.5 - 6 mm ² , -
Connection interfaces (type, feed-through cross section)	Network: Ethernet cable, cable connection via cable fitting M25, standard RS485: 2-wire, cable connection via cable fitting M16 max. 1.5 mm
Temperature monitoring	Yes
Cooling (free convection (K)/fan (L))	L
Degree of contamination PD	2
Noise emission [dB(A)]	61
DC isolator switch	Built-in
Housing	Aluminium
H x W x D [mm]	760 x 500 x 425
Total weight [kg]	73(XL version) 71(Basic + M version)
CE conformity	Yes

Table 2: Mechanical data

* With a supply voltage of 240 V or higher the lower MPP voltage is increasing accordingly.

4.3 Environmental conditions

Product name: KACO blueplanet 50 TL3 M1 WM OD xxxx		
Last 4 characters of product name/item number	IIGB 1001450 / IIGR 1001601 IIGM 1001336 / IIGM 1001582 IIGX 1001430 / FRGX 1001555	FRGX 1001581
Distance from coast	> 2000 m	> 500 m*
Ambient temperature range [°C]	-20 ... +60 Power reduction above +50	
Humidity range (non-condensing) [%]	100	
Maximum installation elevation (m above mean sea level)	3000 (Power reduction above 2000)	
Protection rating according to EN 60529	IP65 (tested according to DIN EN 60068-2-52)	

Table 3: Environmental conditions

* For installation in aggressive environmental conditions (e.g. possibility of corrosion), you must contact the KACO Sales team (pv-projects@kaco-newenergy.de).

5 Transportation and Delivery

Every inverter leaves our factory in proper electrical and mechanical condition. Special packaging ensures that the units are transported safely. The shipping company is responsible for any transport damage that occurs.

5.1 Scope of delivery

- 1 inverter
- 1 wall bracket
- 1 installation kit
- 1 insulating tube (for interface cables)
- 1 set of DC plug connectors (only for the XL device version)
- 1 set of documentation (DE, EN, quick start guide in other languages)

Checking your delivery

1. Inspect your inverter thoroughly.
2. Immediately notify the shipping company in case of the following:
 - Damage to the packaging that indicates that the inverter may have been damaged
 - Obvious damage to the inverter.
3. Send a damage report to the shipping company immediately.

The damage report must be received by the shipping company in writing within six days following receipt of the device. We will be glad to help you if necessary.

5.2 Transportation

CAUTION

Impact hazard, risk of breakage to the inverter

- › Pack the inverter securely for transport.
- › Carefully transport the inverter using the carrying handles of the packaging box.
- › Do not subject the inverter to shocks.

For safe transportation of the inverter, use the holding openings in the carton.

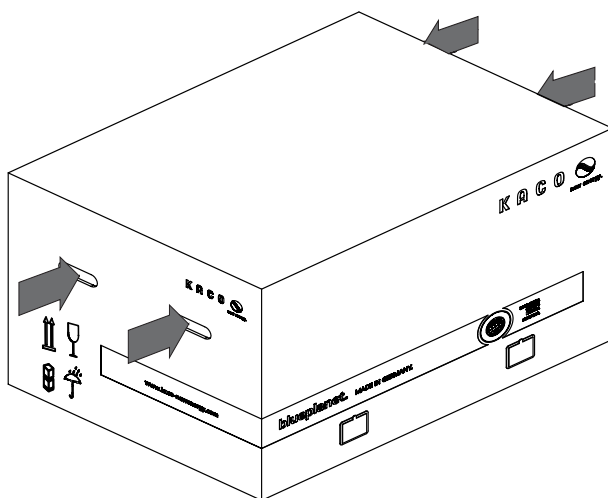

Packaging (folding cartons)	540 x 810 x 580
(H x W x D (mm))	81 (XL version)
Total weight [kg]	79 (Basic + M version)

Figure 6: Transportation of the inverter

Table 4: Dimensions and weight

6 Mounting



DANGER



Risk of fatal injury due to fire or explosions!

Fire caused by flammable or explosive materials in the vicinity of the inverter can lead to serious injuries.

- › Do not mount the inverter in an area at risk of explosion or in the vicinity of highly flammable materials.

Installation location

- As dry as possible, climate-controlled, with the waste heat dissipated away from the inverter
- Air circulation should not be blocked
- When installing the unit in a control cabinet, provide forced ventilation so that the heat is sufficiently dissipated
- Access to the inverter must also be possible without additional tools
- For outdoor installation, fit the inverters in such a way that they are protected against direct sunlight, moisture and dust penetration
- For easy operation, ensure during installation that the display is slightly below eye level.

Wall surface

- Must have adequate load-bearing capacity
- Must be accessible for installation and maintenance
- Must be made of heat-resistant material (up to 90 °C)
- Must be flame resistant
- Minimum clearances to be observed during assembly: see Figure 11 on page 15.



NOTE

Access by maintenance personnel for service

Any additional costs arising from unfavourable structural or mounting conditions will be billed to the customer.

CAUTION

Property damage due to gases that have an abrasive effect on surfaces when they come into contact with ambient humidity caused by weather conditions.

The inverter housing can be severely damaged by gases (ammonia, sulphur, etc.) if it comes into contact with ambient humidity caused by weather conditions.

If the inverter is exposed to gases, it must be mounted so that it can be seen at all times.

- › Perform regular visual inspections.
- › Immediately remove any moisture from the housing.
- › Take care to ensure sufficient ventilation of the inverter.
- › Immediately remove dirt, especially on vents.
- › Failure to observe these warnings may lead to inverter damage which is not covered by the KACO new energy GmbH manufacturer warranty.

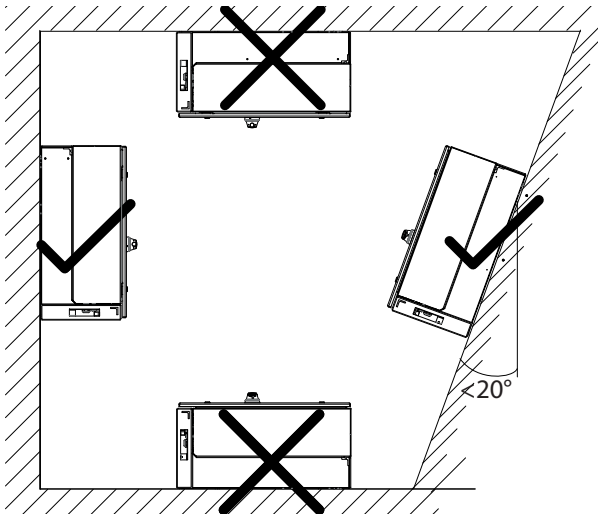

Figure 7: Instructions for wall mounting

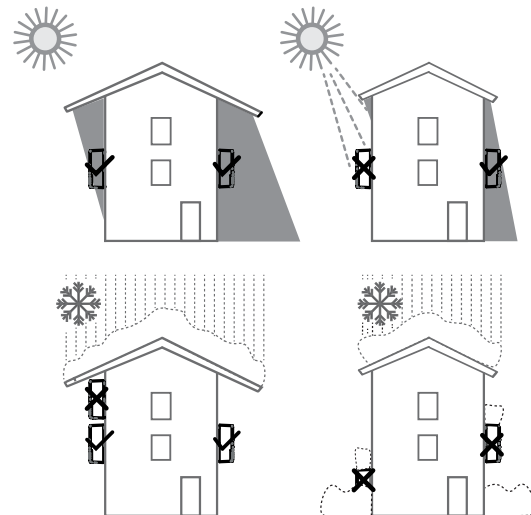

Figure 8: Inverter for outdoor installation

CAUTION

Use suitable mounting parts.

- › Use mounting material suitable for the subsurface or the mounting material included in the delivery.
- › Mount the inverter upright on a vertical wall only.
- › For a free-standing mounting an incline of 20° is permissible.
- › For upright installation outdoors: Weather-proof base required.

6.1 Unpacking

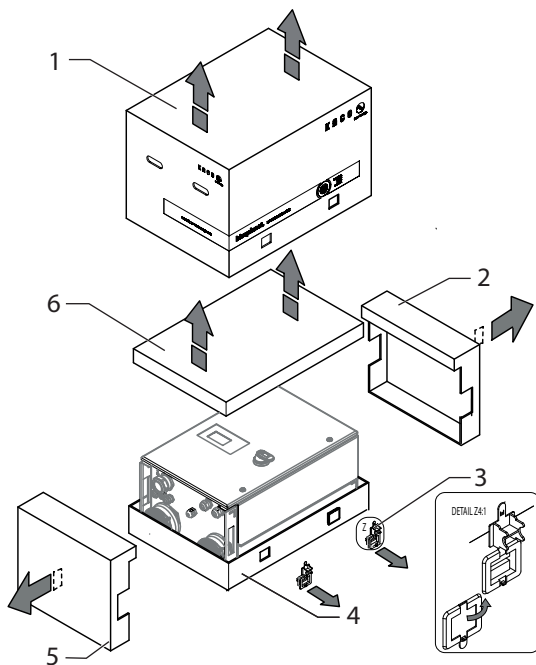

Figure 9: Opening the packaging

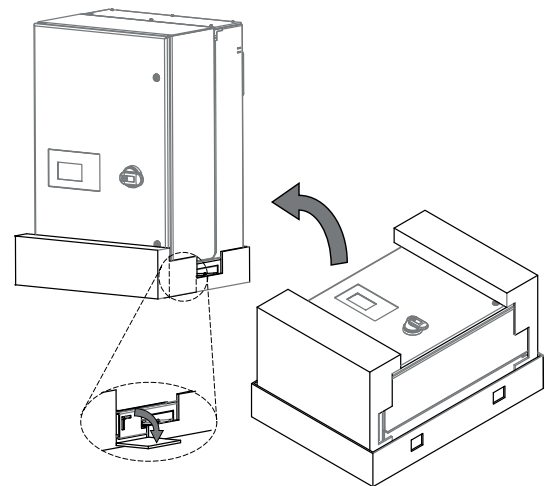

Figure 10: Raise the device

Key

1	Cover	4	Base
2	Side section - upper	5	Side section - lower
3	Clamp (4x)	6	Cardboard box with wall holder and mounting kit

⚠️ Authorised electrician

⚠️ CAUTION



Risk of injury caused by excessive physical strain.

Lifting the device for transportation or to change location can lead to injuries (e.g. back injuries).

- › The unit should only be lifted using the openings provided or a transportation device.
- › The unit must be transported and installed by at least 2 persons.

EN

Unpacking the unit

- The unit is transported to the installation location.
- 1. Remove the plastic band from the pallet and packaging.
- 2. Pull the clamp off the packaging.
- 3. Lift up the cover and set the cardboard box with wall holder and accessories aside.
- 4. Set the unit with base and side sections upright.
- 5. Remove the upper side section and base from the unit.
- » If the unit is in the correct installation position: Proceed with the installation of the wall holder.

6.2 Installing the wall bracket

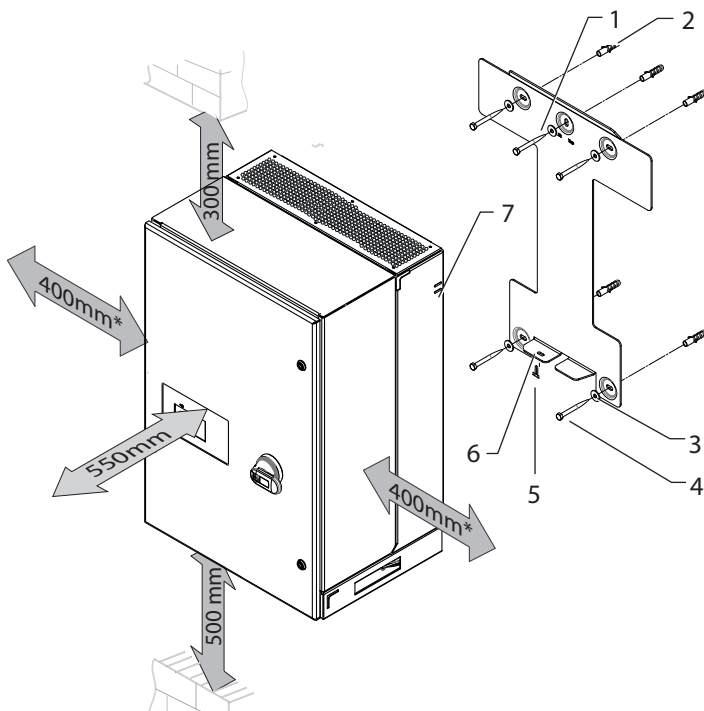

Figure 11: Minimum clearances/mounting

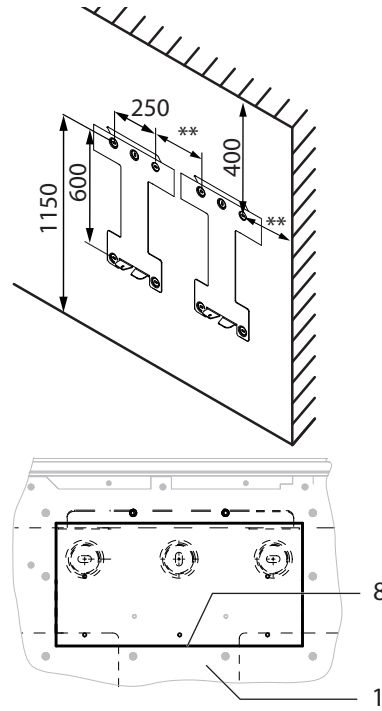

Figure 12: Position of wall holder/suspension

Key

1 Wall bracket	5 Screw for securing purposes (1x)
2 Fixings for mounting	6 Bracket to prevent unit displacement
3 Lock washer	7 Marking as installation aid
4 Screws for mounting (5x)	8 Seating recess

* Recommended clearance: 400 mm / minimum clearance: 120 mm

** recommended clearance: 550 mm / minimum clearance: 370 mm

Installing the wall bracket

- Cardboard box with wall holder and mounting kit removed from packaging and opened.
- 1. Mark the suspension position with a line on the wall surface corresponding to the position of the wall holder (Figure 12).

⚠️ Authorised electrician

2. Mark the positions of the drill holes using the slots in the wall bracket.
NOTE: The minimum clearances between two inverters, or the inverter and the ceiling/floor have already been taken into account in the diagram (Figure 12 on page 15).
 3. Fix wall mount to the wall with the supplied mounting fixtures in the mounting kit.
NOTE: Make sure that the wall bracket is aligned correctly.
- » Proceed with the installation of the unit.

CAUTION

Power reduction due to heat accumulation.

In the event of insufficient ventilation and the resulting heat build-up, the unit will go into power regulation mode.

- › Observe minimum clearances and provide for sufficient heat dissipation.
- › All objects on the inverter housing must be removed during operation.
- › Ensure that foreign bodies do not get in (cable residue, cable ties) via the heat sink guard plate. Otherwise cleaning must take place before initial operation.

6.3 Installing the unit

⚠️ WARNING

Risk of injury from improper lifting and transport.

If the unit is lifted improperly, it can tilt and result in a fall even if a lifting device is used.



- › Always lift the unit vertically using the openings provided.
- › **Optional:** Only use a suitable transport device with an adequate load capacity and secure it against slippage.
- › Use a climbing aid for the chosen installation height.
- › Wear protective gloves and safety shoes when lifting and lowering the unit.

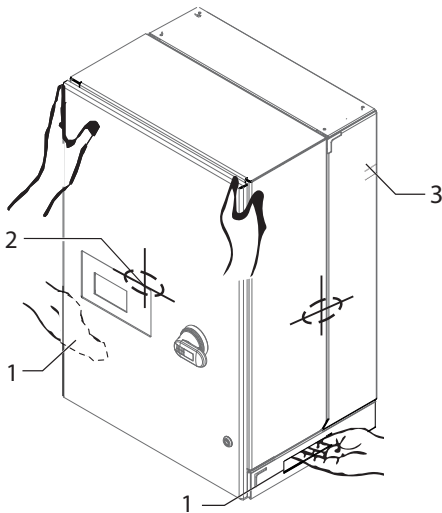

Figure 13: Lift the unit using the opening

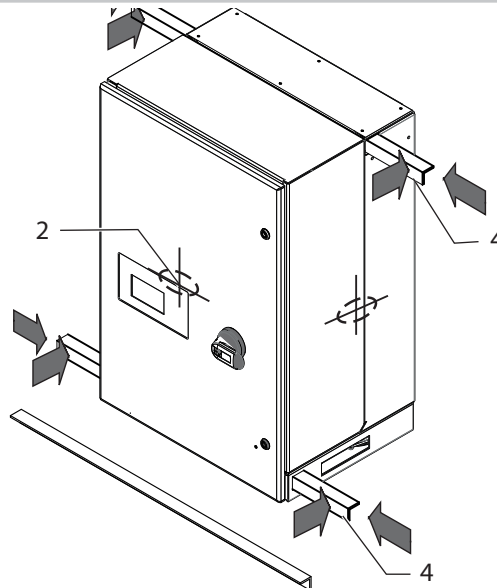

Figure 14: Lift the unit with a transport device

Key

1	Contact	4	Transport device (not supplied) - recommended
2	Centre of gravity	Angle profiles: 2x (Alu blank L30x 30x 3x 800 mm)	
3	Marking for insertion into wall holder		

⚠️ Authorised electrician

Lifting and installing the unit

- ⌚ Wall holder mounted.
- 1. Use the lateral openings for lifting **or** insert the transport device into the lateral slots and lift the unit at the designated positions (see Figure 14 on page 16).
- 2. Hang the inverter on the wall holder using the suspension brackets on the back of the housing.

NOTE: Keep in mind that the lower marking on the housing must protrude over the upper outer contour of the wall holder. (See Figure 15). Ensure that the upper marking is flush with the upper edge of the outer contour when lowering the unit. The outer contour of the wall holder must be flush with the outer contour of the housing.

- 3. Insert the provided screw into the bracket on the wall holder and fasten the inverter to secure against displacement.

Alternatively: At this point, the screw mentioned at step 3 can be replaced by a special screw as anti-theft protection.

- » Installation of the inverter is complete. Proceed with the electrical installation.

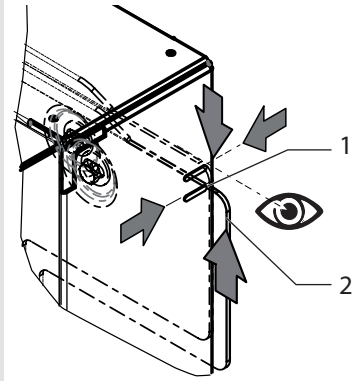

Figure 15: Insertion aid in wall holder

Key

- 1 Marking on housing
- 2 Outer contour of wall holder

7 Electrical connection

⚠️ DANGER

Lethal voltages are still present in the terminals and cables of the inverter even after the inverter has been switched off and disconnected!

Severe injuries or death will occur when touching the cables and terminals in the inverter.

Only appropriately qualified and authorised electricians may open and install the inverter.

The inverter must be mounted in a fixed position before being connected electrically.



- › Comply with all safety regulations and current technical connection specifications of the responsible power supply company.
- › Switch off the grid voltage by turning off the external circuit breakers.
- › Check that the AC and DC cables are completely free of current using a clip-on ammeter.
- › Reduce any DC voltage that is present by covering the module surface.
- › Connect the inverter only after the aforementioned steps have been taken.

7.1 Switching off the unit

Switching off the unit

- 1. Switch the DC isolator switch from 1 (ON) to 0 (OFF).
- 2. Press in the safety catch (1) from behind.
- 3. Attach the hanging lock (2) to the safety catch.

⚠️ DANGER



A measurement in a live state may be required for tests.

Only appropriately qualified and authorised electricians may open the inverter.

- › Observe all safety regulations against harmless contact with live materials.

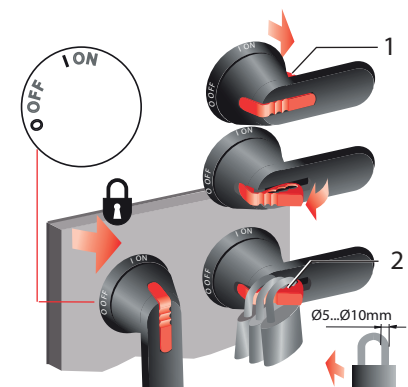

Figure 16: Lock DC isolator switch to prevent reconnection

⚠️ Authorised electrician

7.2 Preparing the AC connection

7.2.1 Opening the unit

Opening the housing door

- ⊖ Unit switched off and secured against restart.
 - ⊖ Wipe off any moisture on the housing door frame to nullify any potential liability this could cause.
1. Open the housing door by unlocking the upper and lower lock with the double-bit key provided.
 2. Open the housing door carefully.
- » Proceed to lock the housing door in place.

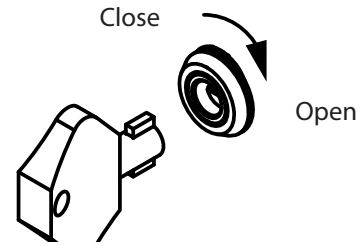

Figure 17: Opening the housing door

Locking the housing door in place

- ⊖ Housing door opened.
1. Swing the latch lever into the slot.
 2. Secure the lever so the door does not swing open unexpectedly.
- » Survey the connection area, observe the cable requirements and proceed to connect up the unit.

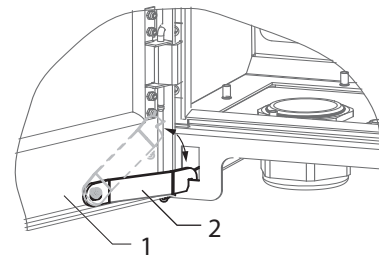

Figure 18: Lock the housing door in place

Key

- 1 Housing door
- 2 Latch lever

7.2.2 Surveying the connection area

The connection for the AC supply is located inside the housing. The DC input source is connected either inside or outside the housing depending on the device version (Basic, M or XL).

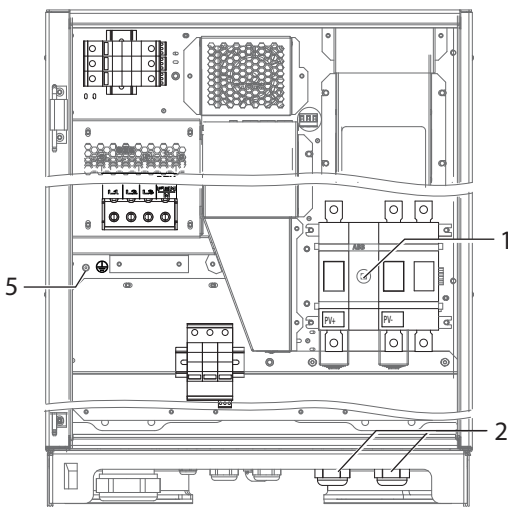

Figure 19: Connection area: blueplanet 50.0 TL3 Basic + M

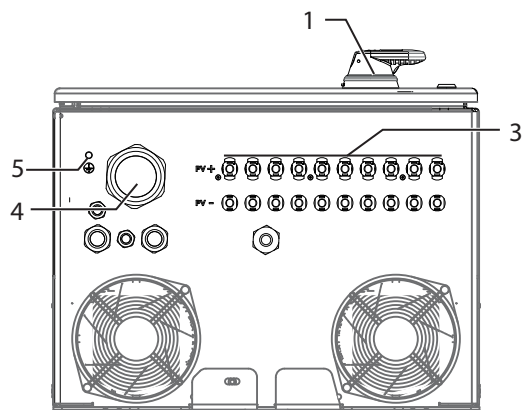

Figure 20: Connection area: blueplanet 50.0 TL3 XL

Key

- | | |
|---|---|
| 1 DC isolator switch | 4 Cable fitting (M63) for AC connection |
| 2 Cable fitting for DC connection (M version) | 5 Earthing bolt |
| 3 Connector for DC connection (XL version) | |

⚠️ Authorised electrician

7.2.3 Cable and fuse requirements

Note the following cable cross-sections and the required tightening torques:

	AC connection	DC connection (Basic + M)	DC connection (XL)
Max. cable cross-section without wire sleeves	95 mm ² (AL or CU)	95 mm ² (max. 120 mm ²) - Use an AL-CU cable lug for an aluminium cable.	2.5-6 mm ² (10x DC plug connectors)
Max. conductor cross-section	95 mm ² with wire sleeves	95 mm ² (max. 120 mm ²) Screw M8 - ring cable lug on M8/Ø 9mm ²	-
Length of insulation to be stripped off	25 mm	depending on the cable lug used	
Tightening torque	10 Nm	15-22 Nm	- (DC plug connector)
Recommended cable type	PV1-F or UL-certified solar cables (ZKLA), AWG 10–14		

Table 5: Recommended cable cross-sections and tightening torques

The unit versions Basic, M and XL also differ in the following ways:

	Basic	M	XL
DC overvoltage protection	-	Base	Base + overvoltage conductor (SPD), type I + II
AC overvoltage protection	-	Base	Base
Overvoltage conductor (SPD)	-	Can be retrofitted on the DC and AC side	DC side built-in, can be retrofitted on the AC side
String fuses	To be provided externally on-site		15A fuses installed internally
Combiner box	To be provided externally on-site		Installed internally
Protection class	1		
Overvoltage category	III		

Recommended conductor cross-sections and fuse protection of NYM cables for fixed wiring according to VDE 0100 part 430

For cable lengths up to 20 m, use the named conductor cross-sections. Longer cable lengths require larger conductor cross-sections.

Device version:	Conductor cross-section	Fuse protection: gL safety fuses
blueplanet 50.0 TL3 Basic, M	min. 25 mm ²	min. 100 A for 25 mm ² conductor cross-section max. 125 A for 35 mm ² conductor cross-section
blueplanet 50.0 TL3 XL	min. 25 mm ²	

Table 6: Recommended conductor cross-sections and fuse protection of NYM cables

7.3 Connection to the power grid

The power connection cables are connected to the AC terminals on the left of the connection area (see Figure 21 and Figure 24).

- Making the grid connection (TN-S system, TN-C-S system, TT system)**
- ⊕ Use cables with 5 wires (L1: brown, L2: black, L3: grey, N: blue, PE: green/yellow).
 - Check the grid voltage and compare with "VAC nom" on the name plate.
 - 3. Loosen cable fitting for AC connection.
 - 4. Remove the outer cladding of the AC cables.
 - 5. Insert the AC cables through the cable fitting into the connection area.
 - 6. Strip the insulation from the AC cables.
 - » Making the grid connection.

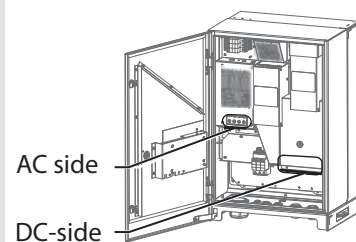

Figure 21: Connection terminals for M version

⚠️ Authorised electrician

EN

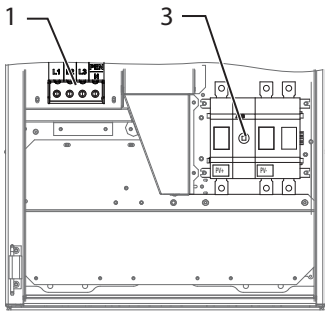

Figure 22: blueplanet 50.0 TL3 - Basic version

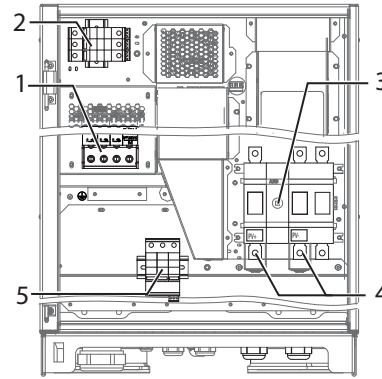

Figure 23: blueplanet 50.0 TL3-M version

Key

1	AC connection terminals	4	DC connection with protection against contact
2	Base AC overvoltage protection	5	Base DC overvoltage protection
3	DC isolator switch		

Making the grid connection (TN-C system)

- ⊖ Use cables with 4 wires (L1: brown, L2: black, L3: grey, PEN: green/yellow).
- 1. Check the grid voltage and compare with "VAC nom" on the name plate.
- 2. Loosen cable fitting for AC connection.
- 3. Remove the outer cladding of the AC cables.
- 4. Insert the AC cables through the cable fitting into the connection area.
- 5. Strip the insulation from the AC cables.
- » Making the grid connection.

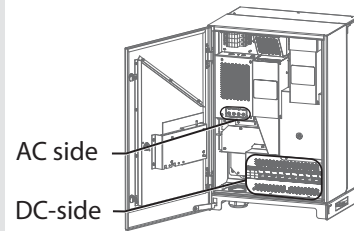

Figure 24: Connection terminals XL version

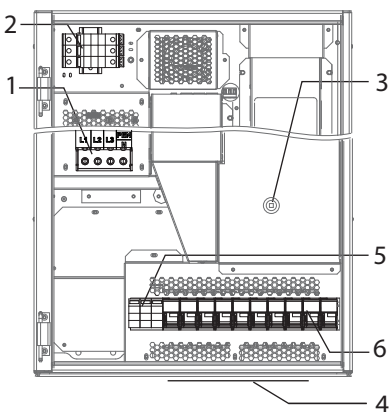

Figure 25: blueplanet 50.0 TL3-version XL

Key

1	AC connection terminals	4	DC connection
2	Base AC overvoltage protection	5	DC overvoltage conductor (SPD), type 1+2
3	DC isolator switch	6	DC fuses

 **Authorised electrician**
Making the grid connection (5 core connection for TN-S system, TN-C-S system, TT-System)

- Insert L1, L2, L3, N and PE through the cable fitting into the AC connection area.
- 1. Remove the cover over the four fastening screws.
- 2. Unscrew the screws for the contact bridge and remove the contact bridge.
- 3. Refit the cover using the four fastening screws.
- 4. Connect the PE line to the earthing bolt.
- 5. Connect cables in accordance with the labels on the PCB terminals (Figure 26).
- 6. Check for secure fit of all connected cables in accordance with the tightening torque (see Table 5 on page 19).
- 7. Tighten the cable fitting.
- » The inverter is now connected to the power grid.

NOTE

If there is a 5-core connection, an inserted contact bridge will trigger any RCD that is present. You must therefore follow the above instructions carefully.

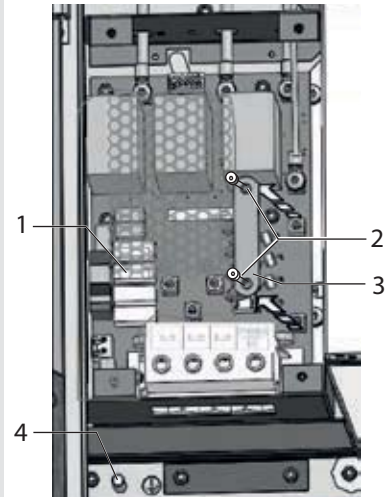

Figure 26: 5-core connection

Key

- 1 Cover
- 2 Screws for contact bridge
- 3 Contact bridge
- 4 Earthing bolt

Making the grid connection (4-core connection to TN-C system)

- Insert L1, L2, L3, PEN through the cable fitting into the AC connection area.
- 1. Connect cables in accordance with the labels on the PCB terminals (Figure 27).
- 2. Check for secure fit of all connected cables in accordance with the tightening torque (see Table 5 on page 19).
- 3. Tighten the cable fitting.
- » The inverter is now connected to the power grid.

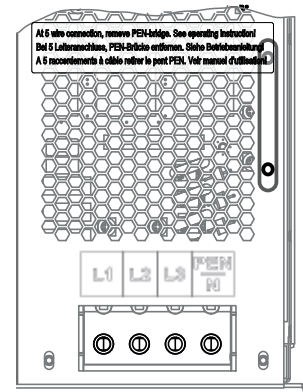

Figure 27: 4-pole connection

NOTE

An AC-side disconnection unit must be provided during the final installation stage. This cut-off mechanism must be installed so that it can be accessed at any time without obstruction.

NOTE

If a residual current circuit breaker is necessary due to the installation specification, a type A residual current circuit breaker must be used. If the type **A** is used, the insulation threshold must be set **to greater than/equal to (\geq) 200kOhm** in the "Parameters" menu (section 8.3 on Page 42). For questions regarding the appropriate type, please contact the installer or our KACO new energy customer service.

 **Authorised electrician**
**NOTE**

If the cable impedance is high (i.e. long grid-side cables), the voltage at the grid terminals of the inverter will increase during feed-in to the grid. The inverter monitors this voltage. If this exceeds the country-specific grid overvoltage limit value, the inverter switches off.

- › Ensure that the cable cross-sections are sufficiently large or that the cable lengths are sufficiently short.

7.4 Preparing the DC connection

7.4.1 Configuring the DC plug connector

The unit variants Basic, M and XL differ in the DC connection area. Pre-configured DC plug connectors are required for connection in the XL version.

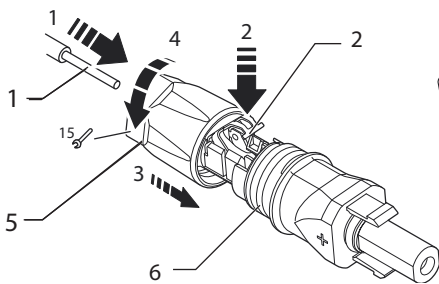

Figure 28: Insert wires

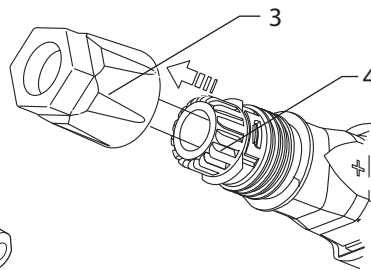

Figure 29: Slide insert into sleeve

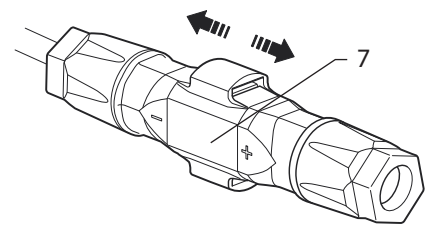

Figure 30: Check fastening

Key

1	Wire for DC connection	5	Cable fitting
2	Spring	6	Contact plug
3	Insert	7	Coupling
4	Sleeve		

Configuring the DC plug connector

NOTE: Before proceeding with the isolation ensure that you do not cut any individual wires.

1. Isolate wire for DC connection by 15 mm.
2. Insert isolated wire with twisted ends carefully up to the end stop.

NOTE: Wire ends must be visible in the spring.

3. Close the spring so that the spring latches.
 4. Slide insert into sleeve.
 5. Tighten cable fitting with the help of a 15 mm fork wrench applying a torque of 2 Nm.
 6. Join insert with contact plug.
 7. Check latch by lightly pulling on the coupling.
- › Make the electrical connection.

**NOTE**

The permissible bending radius of at least 4x the cable diameter should be observed during installation. Excessive bending force may negatively impact the protection rating.

- › All mechanical loads must be absorbed in front of the plug connection.
- › Rigid adaptations are not permitted on DC plug connectors.

 **Authorised electrician**

EN

7.4.2 Designing the string fuse

CAUTION

Damage to PV generator in case of faulty design of string fuses.

If the string fuses are too large, the PV generator can be damaged by excessive current.

- › Select suitable string fuses depending on possible short-circuit currents and the cable cross-sections used.

Delivery state as well as the type and number of the integrated string fuses:

Equipment types	Delivery state	Fuses supplied
blueplanet 50.0 TL3 (XL)	integrated fuses	10x PV fuse 14 x 51 mm, 15 A, 1100 V/DC

7.4.3 Checking the PV generator for a ground fault

 **DANGER**

Risk of fatal injury due to electric shock!



Severe injury or death will result if the live connections are touched. When there is solar radiation, DC voltage will be present at the open ends of the DC cables.

- › Only touch the PV generator cables on the insulation. Do not touch the exposed ends of the cables.
- › Avoid short circuits.
- › Do not connect any strings with a ground fault to the unit.

Checking the PV generator for a ground fault

1. Determine the DC voltage between:
 - protective earth (PE) and the positive cable of the PV generator
 - protective earth (PE) and the negative cable of the PV generator.

If stable voltages can be measured, there is a ground fault in the DC generator or its wiring. The ratio between the measured voltages gives an indication as to the location of this fault.
2. Rectify any faults before taking further measurements.
3. Determine the electrical resistance between:
 - protective earth (PE) and the positive cable of the PV generator
 - protective earth (PE) and the negative cable of the PV generator.

In addition, ensure that the PV generator has a total insulation resistance of more than 2.0 MOhm, since the inverter will not feed in if the insulation resistance is too low.
4. Rectify any faults before connecting the DC generator.



NOTE

The threshold value from which the insulation monitor reports an error can be set in the “Parameter” menu.

7.4.4 Designing the PV generator



NOTE

In accordance with IEC 61730 Class A, connected PV modules must be dimensioned for the DC system voltage provided, and at least for the value of the AC grid voltage.

	P_{max}	$I_{rated,max}$ MPP tracker	$I_{SC,max}$ MPP tracker
MPP tracker	<51.6 kW	<90 A	<150 A

 **Authorised electrician**

7.5 Connecting the PV generator

The PV generator is connected on the right in the connection area (see Figure 19 and Figure 20 on page 18).

 **DANGER**

Risk of fatal injury due to contact voltages! Under the action of light, solar modules can generate lethal voltages that cannot be disconnected.



- › During installation: Electrically disconnect the DC positive and DC negative from the protective earth (PE).
- › The DC connection may only be made while power is switched off. Cover solar modules if necessary.
- › Only touch the PV generator cables on the insulation. Do not touch the exposed ends of the cables.
- › Avoid short circuits.

CAUTION

Damage to the device in case of faulty configuration of the DC connector.

A faulty configuration of the DC connector (polarity +/-) causes equipment damages in the DC connection if it is connected permanently.

- ☞ Please check polarity (+/-) of the DC connector before connecting the DC generator
- ☞ Before using the solar modules, check the vendor's calculated voltage values against those actually measured. The DC voltage of the PV system must not exceed 1100V at any time.

Connecting the PV generator (Basic + M version)

- PV generator is dimensioned according to the performance characteristics of the unit.
- 1. Unscrew the cable fittings.
- 2. Remove the outer cladding of the DC cables.
- 3. Insert the DC cables through the cable fittings into the connection area (see Figure 19 on page 18).
- 4. Strip the insulation from the DC cables.
- 5. Fit the DC cables with a ring cable lug.
- 6. Remove the protection against contact from the PV+ and PV- terminal.
- 7. Screw the cable ends onto the DC connections (PV+/PV-) according to the polarity of the PV generator (tightening torque - see Table 5 on page 19).
- 8. Check secure fit of all connected cables.
- 9. Remove the protection against contact from the PV+ and PV- terminal.
- 10. Tighten the cable fittings.
- » The inverter is connected to the PV generator.

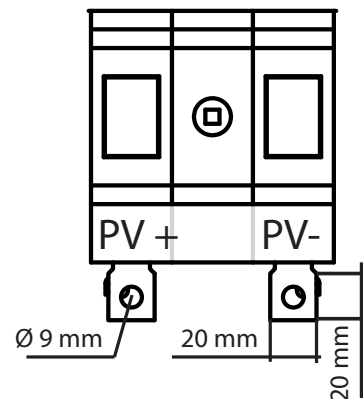

Figure 31: PV connection (blueplanet 50.0 TL3 - Basic + M)

Connecting the PV generator (XL version)

- PV generator is dimensioned according to the performance characteristics of the unit.
- 1. Remove protective cap from the DC connection plugs.
- Note:** For each plug connector pair, the power output can be connected in relation to the string fuse size used.
- 2. Connect the PV generator to the DC plug connectors on the underside of the unit according to the polarity of the PV generator.
- 3. Meet the requirements of protection rating IP65 by closing the unused plug connectors with protective caps.
- 4. Put on cover to safeguard the DC connections and latch into place by pressing it.
- » The inverter is connected to the PV generator.

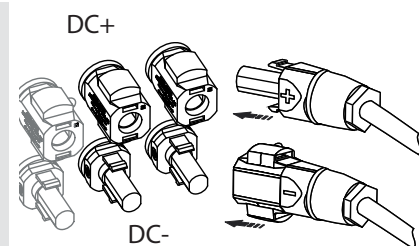

Figure 32: PV connection (blueplanet 50.0 TL3 - XL)

 **Authorised electrician**

7.6 Grounding the housing

EN

DANGER

Dangerous voltage due to two operating voltages!

Severe injuries or death may occur if the cables and terminals in the device are touched.

The discharge time of the capacitors is up to 5 minutes.



- › Only appropriately qualified and authorised electricians may open and maintain the inverter.
- › Before opening the unit: Disconnect the PV generator and grid and wait at least 5 minutes.
- › Establish ground connection under all circumstances before connecting the supply circuit.
- › Make sure that the device is isolated from the public power supply and the system power supply before starting work.

In addition to the outer housing earth, there is a grounding point within the housing. Please observe any national installation regulations in this respect.

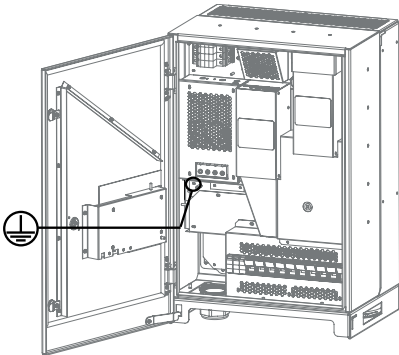

Figure 33: Grounding point in the AC connection area

Grounding the housing

- Housing opened and door secured with the latch lever provided.
- 1. Loosen the AC cable fitting and insert the earth cable into the housing.
- 2. Remove the insulation from the grounding cable.
- 3. Furnish the insulated grounding cable with a ring cable lug.
- 4. Loosen nut and lock washer at the marked grounding point.
- 5. Lay the grounding cable onto grounding point and attached with a nut and lock washer.
- 6. Lay the grounding cable so that it is not under tension and attach with a cable fitting.
- » Housing is properly grounded.

7.7 AC and DC overvoltage protection upgrade



NOTE

The M and XL versions of the unit series blueplanet 50.0 TL3 allows you to upgrade the AC and DC lightning and overvoltage protection in a straightforward and cost-efficient manner.

In this respect, please refer to the documentation "blueplanet 50.0 TL3 Application note – Installing surge protection device" on our website.

 **Authorised electrician**

7.8 Connecting the interfaces

All interfaces are located on the communication circuit board on the inside of the housing door.

CAUTION

Damage to the unit from electrostatic discharge

Components inside the unit can be damaged beyond repair by static discharge.

- ☞ Note the ESD protective measures.
- ☞ Earth yourself before touching a component by touching a grounded object.



NOTE

Due to the installation position of the communication circuit board, this must be specially safeguarded against moisture and exposure to dust.

- › Make sure that no moisture or dust impacts on the circuit board during installation. Moisture and dust particles must be removed immediately. In doing so, disassembly of the circuit board may be necessary.

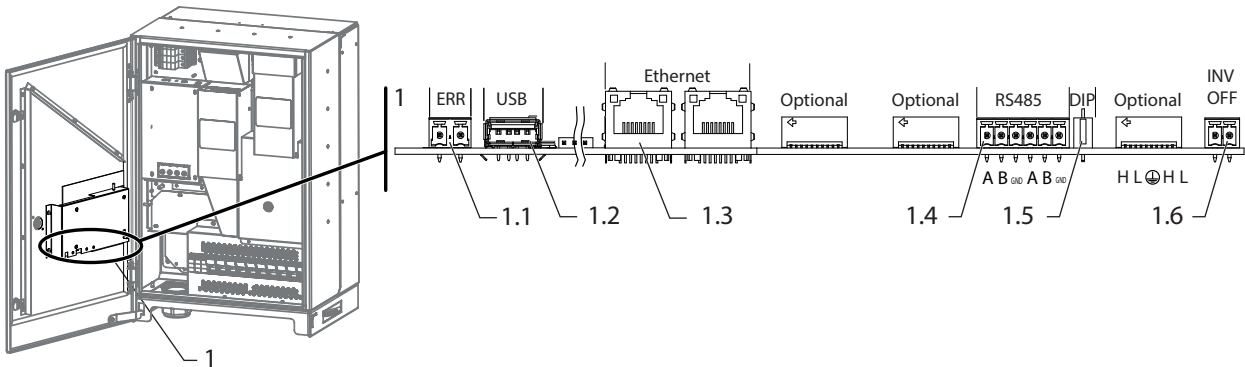

Figure 34: Communication circuit board: Connection and assignment of the interfaces

Key

1	Communication circuit board	1.4	RS485 - Connection for data loggers
1.1	ERR - Connection for fault signal relay	1.5	DIP switch - Activate terminating resistor
1.2	USB - connection for update	1.6	INV OFF - connection for remote control devices
1.3	Ethernet - Connection for communication		

DANGER

Risk of fatal injury due to electric shock!

Severe injury or death may result from improper use of the interface connections and failure to observe protection class III.

- › The SELV circuits (SELV: safety extra low voltage) can only be connected to other SELV circuits with protection class III.



NOTE

All signal cables for interfaces must be professionally encased up to the connection using the insulation tube provided before fitting the cable.

⚠️ Authorised electrician

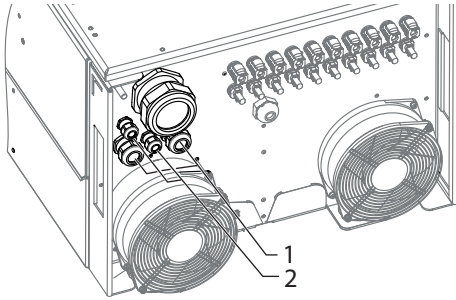

Figure 35: Insert the cable for interfaces

Key

- | | |
|---|---|
| 1 Cable fitting (M25) for feeding the Ethernet cable through. | 2 Cable fitting (M16) for feeding the signal cable through. |
|---|---|

Insert the cable for interfaces

- ⌚ Open the housing and secure the door with the latch lever provided.
- 1. Loosen the cable fitting for feeding the Ethernet cable through.
- 2. Loosen and remove the cover of the cable fitting.
- 3. Remove the sealing insert.
- 4. Thread the connection cable through the cover of the cable fitting and the sealing insert.
- 5. Insert the sealing insert into the cable fitting.
- 6. Loosen the cable fitting for feeding the signal cable through.
- 7. Pass the casing provided around the signal cable (RS485/ERR/Inverter OFF).
- 8. Insert the signal cable.

NOTE: Run the casing right up to the connection point.

» Proceed with cable laying.

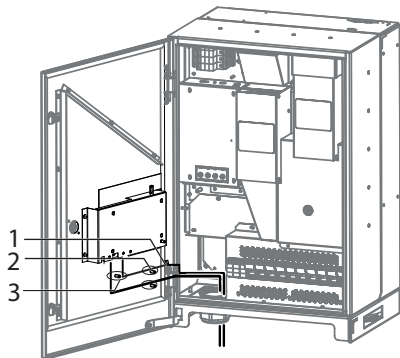

Figure 36: Lay the cables for interfaces

Key

- | | |
|-----------------------|--------------|
| 1 Ethernet cables | 3 Cable ties |
| 2 Threaded stud bolts | |

Laying the cable for interfaces

- ⌚ Open the housing and secure the door with the latch lever provided.
 - ⌚ Lay the Ethernet cables as per the illustration above.
 - 9. Fix the encased signal cable to the threaded stud bolts.
 - 10. Lay all the interface cables so that they are not under tension and the housing door has a full range of motion.
- » Proceed with the connection of the cables.

⚠️ Authorised electrician

7.8.1 Connecting the fault signal relay

The contact is designed as an N/O contact and is labelled "ERR" on the circuit board.

Maximum contact load

DC	30 V/1 A
----	----------

- Connecting the fault signal relay**
1. Attach the connection cables to the terminal clamps.
 2. Tighten the cable fitting.

7.8.2 Connecting the Ethernet interface



NOTE

The connection plug of an RJ45 cable is larger than the opening of an M25 cable fitting when it is installed. For this reason, remove the sealing insert before installation and thread the Ethernet cable outside of the cable fitting through the sealing insert.



NOTE

Use a suitable network cable of at least category 5. The maximum length of a network segment is 100 m. Ensure that the cable is correctly assigned. The Ethernet connection of the inverter supports auto-sensing. You can use both crossed and 1:1 protectively-wired Ethernet connection cables.

- Connecting an Ethernet cable to the inverter**
1. Connect the connection cable to Ethernet interface.
 2. Attach and tighten the cover of the cable fitting.

- Connecting the inverter to the network**
- ⌚ Connect the Ethernet cable to the inverter.
 - ⌚ Configure the Ethernet interface in the configuration menu.
 - ☞ Connect the Ethernet cable to the network or a computer.
 - ☞ Configure the Ethernet settings and the web server in the Settings menu.

7.8.3 Connecting the RS485 bus



NOTE

Ensure that the DATA+ and DATA- wires are properly connected. Communication is not possible if the wires are reversed!

Different manufacturers do not always interpret the standard on which the RS485 protocol is based in the same way. Note that the wire designations (DATA- and DATA+) for wires A and B may vary from one manufacturer to another.

Wiring diagram

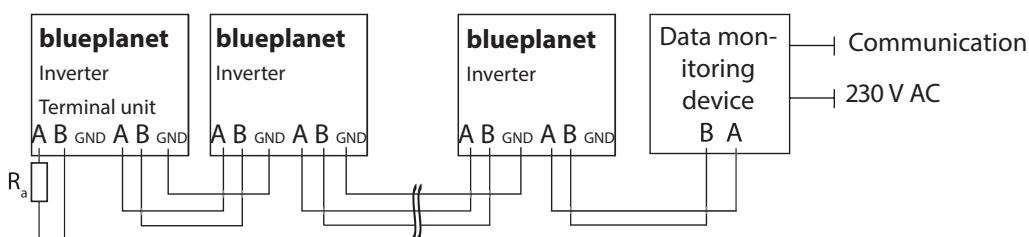

Figure 37: RS485 interface wiring diagram

 **Authorised electrician**
Properties of the RS485 data line

Maximum length of the RS485 bus line	The maximum permitted length of the RS485 bus is 1200m. This length can be reached only under optimum conditions. Cable lengths exceeding 500m generally require a repeater or a hub.
Maximum number of connected bus devices	100 inverters + 1 data monitoring unit
Data line	Twisted, shielded. Recommendations: LI2YCYv (twisted pair) black for laying cable outside and in the ground, 2 x 2 x 0.5 LI2YCY (twisted pair) grey for dry and damp indoor spaces, 2 x 2 x 0.5

Connecting the RS485 bus

☞ To prevent interference during data transmission:

- When connecting wire + and wire -, observe the wire pairing (Figure 38)
 - Do not lay RS485 bus lines in the vicinity of live DC/AC cables.
1. Connect the connection cables to the corresponding connection terminals (see Figure 34 on page 26).
 2. The following must be connected to all inverters and to the data monitor unit in the same way:
 - Wire A (-) to wire A (-)
 - Wire B (+) to wire B (+) and
 - GND with GND (see Figure 37 on page 28)
 3. Tighten the cable fitting.
 4. Activate the terminating resistor on the terminal unit.

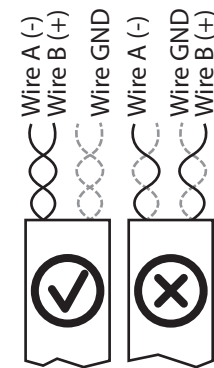

Figure 38: Assignment of twisted-pair wires

NOTE

When using the RS485 bus system, assign a unique address to every bus device (inverter, sensor) and terminate the terminal units (see the “Settings” menu).

Activating the terminating resistor

- ↻ Check whether one of the inverters represents the terminal unit.
- ☞ Only activate the terminating resistor on the communication circuit board of the terminal unit using the DIP switch. (See Figure 34 on page 26)
- » Close the connection area or connect “inverter off”.

7.8.4 Connecting “Inverter Off”

NOTE

The Powador-protect digital output can only be used with suitable KACO inverters. When using devices from other manufacturers or in combination with KACO inverters, external bus coupler circuit-breakers as a minimum must be used for shutting down devices from other manufacturers.

⚠️ Authorised electrician

Connecting and activating "INV OFF" digital input

- ⌚ Can only be used with suitable KACO inverters.
- 1. Connect wire A (+) to the terminal marked "INV+" on the first inverter via the "DOI" terminal of the Powador-protect.
- 2. Connect wire B (-) to the terminal marked "INV-" on the first inverter via the "GND" terminal of the Powador-protect.
- 3. Connect the other inverters to one another as follows:
 - wire A (+) to wire A (+) and wire B (-) to wire B (-).
- 4. Tighten the cable fitting.
- 5. After commissioning: Activate the support for Powador protect in the parameter menu under the "Powador-protect" menu item.

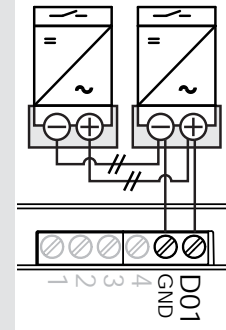

Figure 39: Powador-protect

7.9 Sealing the connection area

1. The requirements of protection rating are met by closing the unused cable fittings with blind caps.
2. Unlatch the housing door lever.
3. Close the housing door and lock it with the double-bit key provided.
 - » The inverter has been mounted and installed.
 - » Start up the inverter.

7.10 Switching on the device

⚠️ DANGER



Lethal voltages are still present in the terminals and cables of the inverter even after the inverter has been switched off and disconnected!

Severe injuries or death will occur when touching the cables and terminals in the inverter. Only appropriately qualified and authorised electricians may start up the inverter.

(FR)

Attachment of safety label in accordance with UTE C 15-712-1

The code of practice UTE C 15-712-1 requires that, upon connection to the French low-voltage distribution grid, a safety sticker showing a warning to isolate both power sources when working on the device must be attached to each inverter.

- ☞ Attach the provided safety sticker visibly to the outside of the inverter housing.

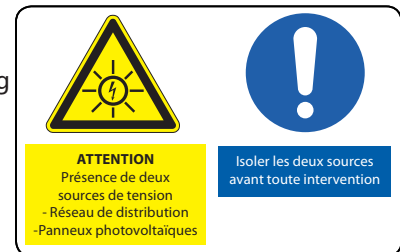

- ⌚ The inverter has been mounted and electrically installed.
- ⌚ Open the hanging lock.
- ⌚ The PV generator supplies a voltage above the configured start voltage.
 1. Connect the grid voltage using the external circuit breakers.
 2. Connect the PV generator using DC isolator switch (0 → 1).
 - » The inverter begins to operate.
 - » During initial start-up: Follow the instructions of the New Connection Wizard.

8 Configuration and Operation

8.1 Controls

The inverter has a backlit LCD display as well as three status LEDs. The inverter is operated using 6 buttons.

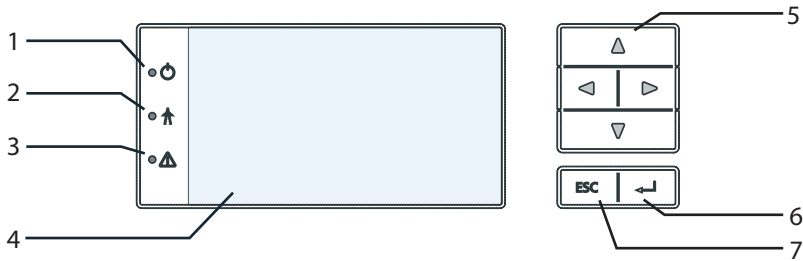

Figure 40: Control panel

Key

1	"Operating" LED	5	4-way button
2	"Feed-in" LED	6	"Enter" key
3	"Fault" LED	7	"ESC" key
4	LCD		









8.1.1 LED indicators

The 3 LEDs on the front of the inverter show the different operating states.







The LEDs can display the following states:



The LED indicators show the following operating status:

Operating status	LEDs	Display	Description
Start			The green "Operating" LED is illuminated if an AC voltage is present, (independently of the DC voltage).
Feed-in start		 	Power fed into the grid or measured values The green "Operating" LED is lit. The green "Feed-in" LED is illuminated after the country-specific waiting period*. The unit is ready to feed in, i.e. is on the grid. You can hear the grid relay switch on.
Feed-in operation		 	Power fed into the grid or measured values The green "Operating" LED is lit. The green "Feed-in" LED is lit. The "Feed-in" icon appears on the LC display. The unit feeds into the grid.

* The waiting period ensures that all grid parameters are in the permissible ranges.

Operating status	LEDs	Display	Description
Non feed-in operation	 	Status message	The display shows the corresponding message.
	 		
Fault	 	Fault message	The display shows the corresponding message. The red "Fault" LED is illuminated.

8.1.2 Graphical display

The graphical display shows measured values and data and allows the configuration of the inverter using a graphical menu. In normal operation, the backlighting is switched off. As soon as you press one of the control buttons, the backlighting is activated. If no button is pressed for an adjustable period of time, it switches off again. You can also activate or deactivate the backlighting permanently.

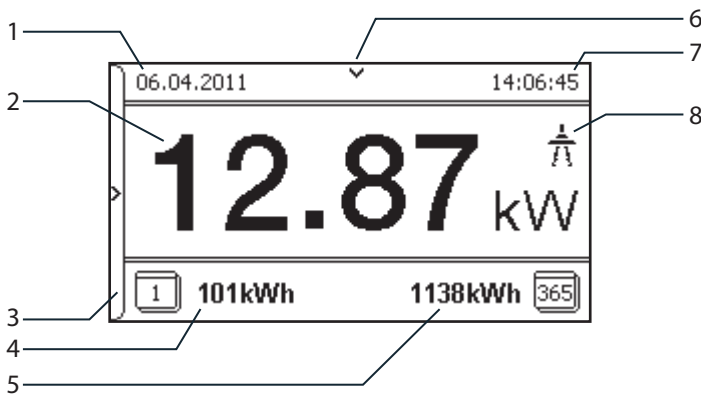

Figure 41: Desktop

Key			
1	Current date	5	Annual yield
2	Current power	6	Indicator for daily yield curve
3	Menu indicator	7	Current time
4	Daily yield	8	Feed-in indicator

After being switched on and after initial commissioning is complete, the inverter displays the start screen (the desktop). If you are in the menu and do not touch the control buttons for 2 minutes, the inverter returns to the desktop. For initial commissioning, see section 8.2 on page 34.

NOTE



Depending on the tolerances of the measuring elements, the measured and displayed values are not always the actual values. However, the measuring elements ensure maximum solar yield. Due to these tolerances, the daily yields shown on the display may deviate from the values on the grid operator's feed-in meter by up to 15%.

NOTE



Calculating efficiency using the measured current and voltage values can lead to misleading results due to the tolerances of the measurement devices. The sole purpose of these measured values is to monitor the basic operation of the system.

8.1.3 Control buttons

The inverter is operated using the 4-way button and the Enter and ESC buttons.

Desktop

Opening the menu

- ⌚ The inverter is operating.
- ⌚ The LCD is showing the desktop.
- ☞ Press the right arrow button.
- » The main menu opens.



Displaying the daily output

- ⌚ The inverter is operating.
- ⌚ The LCD is showing the desktop.
- ☞ Press the down arrow button.
- » The LCD displays the daily yield in a diagram.
- ☞ To return to the desktop, press any button.

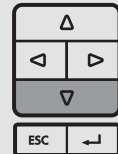

Inverter menu

Selecting a menu option

- ⌚ You have left the desktop. The inverter displays the menu.
- ☞ Use the up and down arrow buttons.

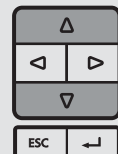

Opening a menu item or a setting

- ☞ Use the right arrow button and the Enter button.

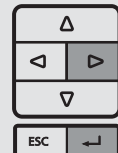

Go to the next higher menu level/discard changes

- ☞ Press the left arrow button or the ESC button.

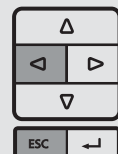

Selecting an option

- ☞ Use the right and left arrow buttons.

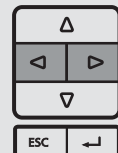

Changing an option/the value of an input field

- ☞ Use the up and down arrow buttons.

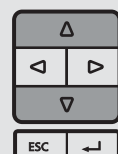

Saving changed settings

- ☞ Press the Enter button.

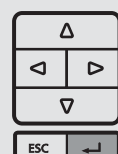

8.2 Initial start-up

When started for the first time, the inverter displays the configuration assistant. It takes you through the settings necessary for the initial start-up.



NOTE

After configuration is completed, the configuration assistant does not appear again when the inverter is restarted. You can then change the country setting only in the password-protected parameter menu. The other settings can still be changed in the Settings menu.



NOTE

The DC power supply must be guaranteed during initial start-up.
The sequence of the settings required for initial start-up is preset in the configuration assistant.

Navigation

- ☞ In order to select a setting, press the up and down buttons.
- ☞ To select the next menu item, press the Enter button.
- ☞ To return to the most recently selected menu item, press the ESC button.
- ☞ Set the required settings.
- ☞ Press the Enter button in the last menu item.

Initial configuration

- ☞ Select the menu language.
- ☞ Select the country of operation with grid type.
- ☞ Set the date and time.
- ☞ To store the set operator country and grid type permanently, confirm these settings with "Yes".
- » You have completed the initial configuration. The inverter begins to operate.

8.3 Menu structure

8.3.1 Display on the LCD

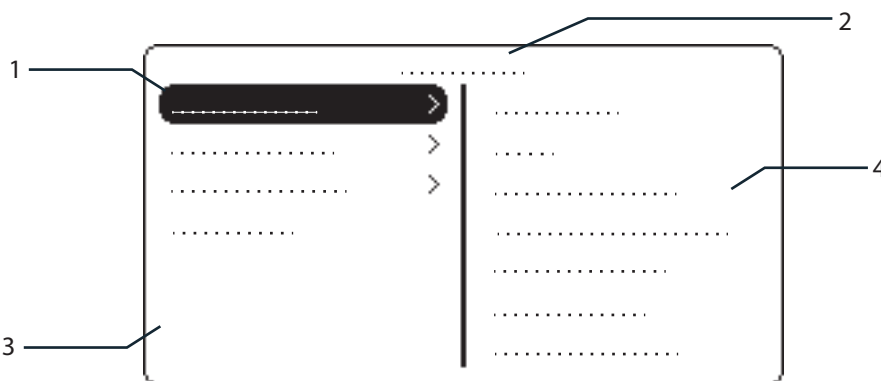

Figure 42: Main menu

Key

1	Selected menu item	3	Menu items of the active menu level
2	Name of the active menu level	4	Menu items of the next lower menu level





8.3.2 Menu structure









































NOTE













The menu items displayed on-screen are dependent on the country and network settings, and may vary according to the type of device. Here, configuration can also be carried out using only the AC power supply.

















Icons used:























	Menu level (0, 1, 2, 3)		Submenu available
	Display menu	EN	Country-specific setting
	Option menu	FR-HTA	Country and grid type-specific setting
	Password protected menu (password can be requested from KACO Service)		

Country-spec. setting	Menu level	Display/setting	Action in this menu/meaning
All countries		Desktop	  Press the right arrow button.
		"Measurements" menu	  Open the menu: Press the right arrow button or the Enter button.
		Generator	 Displays the DC-side voltage, amperage and power.
		Grid	 Displays the AC-side voltage, amperage and power.
		Power control	 Displays the current value of the external power limitation by the grid operator.
		cos-phi	 Indicates the status of the reactive power control.
		Unit temperature	 Displays the temperature in the inverter housing.
		Yield counter	 Displays the yield in kWh.   Reset the counter using the "Reset" key.
		Yield today	 Displays the cumulative yield for the current day.
		Total yield	 Displays the total yield up to now.
		CO2 savings	 Displays the calculated CO ₂ savings (in kg).
		Oper. hrs cntr	 Displays the duration of operation in hours.   Reset the counter using the "Reset" key.
		Oper. time today	 Displays the duration of operation on today's date.
		Total oper. time	 Displays the total operating time.
		Log data view	  Open the menu: Press the right arrow button or the Enter button.   Measurement data can be transferred to a USB stick by selecting it and moving it.

Country-spec. setting	Menu level	Display/setting	Action in this menu/meaning
All countries	1-2-3-4	Day display	<p>Displays the recorded operating data graphically.</p> <ol style="list-style-type: none"> Select the measured value to be displayed. Supported measured values: <ul style="list-style-type: none"> Grid power P DC power of the string P(PV) DC voltage of the string U(PV) Unit temperature Select a day. Press the Enter button. <ul style="list-style-type: none"> » The display shows the selected data. ☞ Press any button to return to the previous menu.
	1-2-3-4	Month display	<p>Displays the recorded operating data graphically.</p> <ol style="list-style-type: none"> Select a month. Press the Enter button. <ul style="list-style-type: none"> » The display shows the selected data. ☞ Press any button to return to the previous menu.
	1-2-3-4	Year display	<p>Displays the recorded operating data graphically.</p> <ol style="list-style-type: none"> Select a year. Press the Enter button. <ul style="list-style-type: none"> » The display shows the selected data. ☞ Press any button to return to the previous menu.
	1-2-3-4	CSV log data	<p>☞ Open the menu: Press the right arrow button or the Enter button.</p>
	1-2-3-4	Decimal separator	<p>☞ Select decimal sign for export of saved operating data.</p>
	1-2-3-4	Save to USB	<p>In this menu, you can export the saved operating data to a connected USB storage device.</p> <p>☺ You have connected a USB storage device to the inverter.</p> <ol style="list-style-type: none"> Select the data to be exported (year, month or day). Press the Enter button. <ul style="list-style-type: none"> » The inverter writes the data to a connected USB storage device.
All countries	1-2-3-4	“Settings” menu	<p>☞ Open the menu: Press the right arrow button or the Enter button.</p>
	1-2-3-4	Language	<p>☞ Select the desired language for the user interface.</p>
	1-2-3-4	Def. total yield	<p>☞ Set the total yield to any value. (If you want to continue the recording from the present value on a replacement unit).</p> <p>☞ Select the “Save” button and confirm with the Enter button.</p>

Country-spec. setting	Menu level	Display/ setting	Action in this menu/meaning
All countries		Interface	<ul style="list-style-type: none"> ☞ Assign a unique RS485 bus address (“RS485 address” menu option). <p>NOTE: The address must not be the same as that of any other inverter or a monitor device.</p>
		Priwatt	<ul style="list-style-type: none"> ☞ Open the menu: Press the right arrow button or the Enter button.
		Activation mode	<ul style="list-style-type: none"> ☞ Activate/deactivate the “Priwatt” function ☞ Select operating mode <p>NOTE: Re-activation depends on the operating mode selected and on the activation conditions.</p>
		Monitoring time	<ul style="list-style-type: none"> ☞ Set time span during which the power threshold must be exceeded without interruption.
		Power threshold	<ul style="list-style-type: none"> ☞ Set power threshold from which the monitoring time up to activation begins.
		Operation mode	<ul style="list-style-type: none"> ☞ Power-dependent: the function remains active until below the set power threshold. ☞ Time-dependent: The function is active independent of the sunlight for the set operation time.
		Operation time	<p>NOTE: The menu option is only available in the “Time-dependent” operation mode.</p> <ul style="list-style-type: none"> ☞ After connection, the function is active for the set operation time.
		Quick start	<ul style="list-style-type: none"> ☞ Reduce the waiting times during the self-test by pressing the “Activate” key.
		Logging interval	<ul style="list-style-type: none"> ☞ Specify the time period between 2 log data recordings.
		Log data backup	<p>NOTE: The unit supports the backing up of all recorded yield data to a connected USB storage device.</p> <ul style="list-style-type: none"> ☞ Activate or deactivate log data backup
		Display	<ul style="list-style-type: none"> ☞ Configure the contrast setting for the display. ☞ Set the length of time without user input after which the backlighting of the LCD switches off. ☞ Alternatively: Permanently activate or deactivate the backlighting by selecting “On” or “Off”.
		Date & time	<p>NOTE: For self-diagnostic purposes, the inverter carries out a daily restart at midnight. To avoid having a restart occur during feed-in operation and to always obtain reliable log data, ensure that the time is correctly set.</p> <ul style="list-style-type: none"> ☞ Set the date and time.





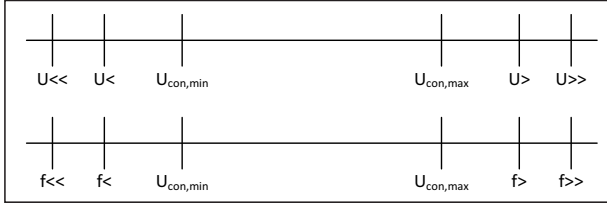



Country-spec. setting	Menu level	Display/setting	Action in this menu/meaning
All countries		Network	<ul style="list-style-type: none"> ☞ Open the menu: Press the right arrow button or the Enter button.
			<ul style="list-style-type: none"> ☞ Activate or deactivate DHCP.
		DHCP	<ul style="list-style-type: none"> ☞ On: Activate DHCP. Once the DHCP server becomes available, the IP address, subnet mask, gateway and DNS server are automatically applied and the aforementioned menu items are hidden. ☞ Off: DHCP deactivated, make settings manually. <p>NOTE: The "IP address", "Subnet masks", "Gateway" and "DNS server" menu options are only displayed with DHCP disabled.</p>
		IP address	<ul style="list-style-type: none"> ☞ Allocate a unique IPv4 address in the network.
		Subnet mask	<ul style="list-style-type: none"> ☞ Assign a subnet mask.
		Gateway	<ul style="list-style-type: none"> ☞ Enter IPv4 address of the gateway.
		DNS server	<ul style="list-style-type: none"> ☞ Enter IPv4 address of DNS server.
		Web server	<ul style="list-style-type: none"> ☞ Open the menu: Press the right arrow button or the Enter button.
		Operation mode	<ul style="list-style-type: none"> ☞ Activate or deactivate the integrated web server.
		Port	<ul style="list-style-type: none"> ☞ Set the port at which the web server can be reached.
		Remote config	<ul style="list-style-type: none"> ☞ If necessary, activate the remote configuration (on/off)
		Remote update	<ul style="list-style-type: none"> ☞ If necessary, activate the remote update (on/off)
		Powador-web	<ul style="list-style-type: none"> ☞ Off: The connection to Powador-web is deactivated. ☞ meteocontrol: The inverter attempts to connect to the Powador-web web portal of meteocontrol. ☞ User-defined 1-4: The inverter attempts to log on via a user-defined portal that was set up by way of remote access.
		Modbus TCP	<ul style="list-style-type: none"> ☞ Open the menu: Press the right arrow button or the Enter button
		Operation mode	<ul style="list-style-type: none"> ☞ Activate/deactivate function.
		Write access	<ul style="list-style-type: none"> ☞ Allow Modbus TCP write accss. <p>NOTE: The "write access" and "Port" menu options are only displayed if TCP is activated.</p>
	Port	<ul style="list-style-type: none"> ☞ Set network port. 	
	Connection status	<ul style="list-style-type: none"> ☞ Indicates the status of the network connection. 	

Country-spec. setting	Menu level	Display/setting	Action in this menu/meaning
All countries		"Parameters" menu	<ul style="list-style-type: none"> ☞ Press the right arrow button or the Enter button. NOTE: The inverter does not display the "Parameters" menu in the standard configuration. To display the Parameters menu: <ol style="list-style-type: none"> 1. Open the menu. 2. Simultaneously hold down the up and down buttons for several seconds.
		Country	<ul style="list-style-type: none">  NOTE: This option influences the country-specific operating settings of the inverter. Please consult KACO service for further information.  1. Enter the four-digit password using the 4-way button. The password is unit-specific. 2. Confirm the entry with the Enter button. 3. Set the desired country setting.
CH, DE, ES, FR, GB, GR, IT, JO, JP, LU, TH, ZA		Grid type/guideline	<ul style="list-style-type: none">  ☞ Select the grid type for the inverter's installation location.
UD		Grid voltage	<ul style="list-style-type: none">  ☞ Set the specified grid voltage for the site where the unit is used (please contact KACO Service)
All countries		Grid parameters	<ul style="list-style-type: none">  ☞ Open the menu: Press the right arrow button or the Enter button.
AT, BG, CZ, FR-OLD, FR-VFR13, FR-VFR14, IE, JP, NL, PL, PT, TR, TW, UD		Overvoltage shutdown, 10-minute average	<ul style="list-style-type: none"> ☞ Activate or deactivate password protection (country-specific password protection!).  ☞ Specify the shutdown threshold for overvoltage trip-off. The 10-minute average for the measured voltage as per EN50160 is used.  ☞ Set period from occurrence of the fault to shutdown of the inverter.
BE  , CH-NS  , CY  , DE-NS  , DK  , LU-NS 			
FR-OLD, FR-VFR13, FR-VFR14, JP, UD		Voltage drop	<ul style="list-style-type: none">  NOTE: The voltage drop between the inverter and the feed-in meter is added to the limit value that was set for grid shutdown according to EN 50160. The limit value can be set from 0-11 V in 1 V increments. ☞ Specify the shutdown value for the voltage drop (0-11 V).
AT, AU, BG, CH-MS, CZ, DE-MS, ES, FR, GB, GR,HR, HU, IE, IL, IN, IT, JO, JP, KR, NL, PL, PT, RO, TH, TR, TW, UD, ZA		Overvoltage shutd.	<ul style="list-style-type: none"> ☞ Specify the shutdown threshold for fast and slow overvoltage shutdown. ☞ Set period from occurrence of the fault to shutdown of the inverter.
		Undervoltage shutd.	<ul style="list-style-type: none"> ☞ Specify the shutdown threshold for fast and slow undervoltage shutdown. ☞ Set period from occurrence of the fault to shutdown of the inverter.

Country-spec. setting	Menu level	Display/ setting	Action in this menu/meaning
Further information on: Grid parameters	1-2-3-4		 <ul style="list-style-type: none"> If the value U< (slow undervoltage shutdown) is set to a value which is greater than the value of U_{con,min}. (minimum restart voltage) using the LC display, then the value of U_{con, min}. is automatically set to the value of U<. If the value U> (slow overvoltage shutdown) is set to a value which is smaller than the value of U_{con,max} (maximum restart voltage) using the LC display, then the value of U_{con, max}. is automatically set to the value of U>. If the value f< (slow underfrequency shutdown) is set to a value which is greater than the value of f_{con,min}. (minimum restart frequency) using the LC display, then the value of f_{con,min}. is automatically set to the value of f<. If the value f> (slow overfrequency shutdown) is set to a value which is smaller than the value of f_{con,max}. (maximum restart frequency) using the LC display, then the value of f_{con, max}. is automatically set to the value of f>.
			<p>NOTE: The inverter is equipped with redundant 3-phase monitoring. If the grid voltage exceeds or drops below the configured values, the inverter switches off. The minimum switch-off threshold can be set in 1 V increments.</p> <ul style="list-style-type: none"> Configure the switch-off values for undervoltage and overvoltage. Where necessary, set period from occurrence of the fault to shutdown of the inverter.
BE, CH-NS, CY, DE-NS, DK, LU-NS	1-2-3-4	Switch-off volt.	<ul style="list-style-type: none"> Set limit value for the slow and fast overfrequency shutdown.
AT, AU, BG, CH-MS, CZ, DE-MS, ES, FR, GB, GR, HR, HU, IE, IL, IN, IT, JO, JP, KR, NL, PL, PT, RO, TH, TR, TW, UD, ZA	1-2-3-4	Overfreq. shutd.	<ul style="list-style-type: none"> Set limit value for the slow and fast underfrequency shutdown.
	1-2-3-4	Underfreq. shutd.	















Country-spec. setting	Menu level	Display/ setting	Action in this menu/meaning
BE, CH-NS, CY, DE-NS, DK, LU-NS	1-2-3-4	Frequency shutdown	<p>The inverter continuously monitors the grid frequency. If the grid frequency exceeds or drops below the configured values, the inverter switches off.</p> <ul style="list-style-type: none"> ☞ Set limit values for underfrequency and overfrequency in +0.1 Hz increments. ☞ Set period from occurrence of the fault to shutdown of the inverter.
All countries	1-2-3-4	Activation condition	<p>NOTE: The inverter checks mains voltage and frequency. The grid feed operation begins if the measured values are within the set ranges.</p> <ul style="list-style-type: none"> ☞ Set minimum and maximum values for switching on.
	1-2-3-4	Connection time	<ul style="list-style-type: none"> ☞ Set period for grid observation (in seconds) when switching on and reconnection after a fault.
	1-2-3-4	DC starting volt.	<p>The inverter begins feed-in as soon as this DC voltage is present.</p> <ul style="list-style-type: none"> ☞ Set the starting voltage.
	1-2-3-4	SPD monitoring	<p>NOTE: Please refer to the application note on our home page if you install the overvoltage protection by yourself.</p> <ul style="list-style-type: none"> ☞ Allows monitoring of the overvoltage protection. ☞ Activate overvoltage protection. <p>NOTE: By activating, an overvoltage protection test is carried out with an appropriate status message.</p>
	1-2-3-4	Constant volt. control	<p>NOTE: Possibility to deactivate the MPP seek mode in order to operate the device with a constant DC voltage.</p> <ul style="list-style-type: none"> ☞ Activate or deactivate the constant voltage controller. ☞ Set value for constant voltage control.
	1-2-3-4	Power limitation	<p>NOTE: The output power of the inverter can be set permanently to a lower value than the maximum output power by the internal power limitation.</p> <p>This may be necessary in order to limit the maximum power rating of the system at the grid connection point, upon the grid operator's request.</p> <ul style="list-style-type: none"> ☞ The value can be protected from the very first power limitation entry. After setting a limitation, the value can only be changed by entering a device-specific password. <ol style="list-style-type: none"> 1. Activate or deactivate password protection 2. Specify activation status (on/off) 3. Specify limit value for maximum feed-in power 4. Confirm the entry with the Enter button.

Country-spec. setting	Menu level	Display/ setting	Action in this menu/meaning
All countries	1-2-3-4	Powador-protect	<p>NOTE: Configures the support for grid shutdown by a Powador-protect connected to the digital input of the inverter.</p> <ul style="list-style-type: none"> ☞ For Auto/On: A Powador-protect is operating in the photovoltaic system and is connected to the inverter at the digital input/output. ☞ Auto: The inverter automatically detects a Powador-protect integrated into the photovoltaic system. ☞ On: The digital signal of the Powador-protect must be present at the digital input of the inverter for the inverter to begin feed-in. ☞ Off: The inverter does not check whether a Powador-protect is integrated into the PV system.
			<p>Insulation resistance</p> <ul style="list-style-type: none"> ☞ Set threshold value (in 1 kOhm steps) at which the insulation monitor reports a fault.
			<p>Power reduction P(f)</p> <ul style="list-style-type: none"> ☞ Open the menu: Press the right arrow button or the Enter button.
			<p>Operation mode</p> <ul style="list-style-type: none"> ☞ Specify operation mode (mode 1 / mode 2 / off)
			<p>Activation threshold</p> <ul style="list-style-type: none"> ☞ Specify activation threshold (if mode 1 or mode 2 is active; this menu item is displayed permanently for IT and IL!).
All countries	1-2-3-4	Deactivation threshold	<ul style="list-style-type: none"> ☞ Specify deactivation threshold (if mode 1 is active; this menu item is displayed permanently for IT and IL!).
			<p>Deactivation time</p> <ul style="list-style-type: none"> ☞ Specify time for power reduction (if mode 1 is active).
All countries	1-2-3-4	Gradient	<ul style="list-style-type: none"> ☞ Set gradient of power limitation function with increasing frequency in % / Hz. The percentage value is based on the rated frequency (if mode 1 or mode 2 is active; this menu item is displayed permanently for IT and IL!).
			<p>Intentional delay</p> <ul style="list-style-type: none"> ☞ Set the power reduction delay in seconds (if mode 1 or mode 2 is active; this menu item is displayed permanently for IT and IL!).
			<p>Transient time</p> <ul style="list-style-type: none"> ☞ Set the power reduction delay in seconds (if mode 1 or mode 2 is active; this menu item is displayed permanently for IT and IL!).
			<p>Output gradient</p> <ul style="list-style-type: none"> ☞ Specify output gradient increase and decrease in ‰ - (per thousand) / minute (if mode 1 or mode 2 is active; this menu item is displayed permanently for IT and IL!).
			<p>Deactivation gradient</p> <ul style="list-style-type: none"> ☞ Specify deactivation gradient in ‰ - (per thousand) / minute (if mode 1 or mode 2 is active; this menu item is displayed permanently for IT and IL!).

Country-spec. setting	Menu level	Display/ setting	Action in this menu/meaning
All countries		Fault ride-through (FRT)	<p>NOTE: The inverter supports dynamic grid support (Fault Ride Through).</p> <ul style="list-style-type: none"> ☞ Open the menu: Press the right arrow button or the Enter button.
		Operation mode	<ul style="list-style-type: none"> ☞ Select control process and activate with Enter key. <p>NOTE:</p> <p>Off: Disables dynamic grid support using dynamic reactive current. Dynamic grid support remains active on account of immunity to interference.</p> <p>Q priority: Dynamic grid support active on account of immunity to interference and dynamic reactive current. The inverter feeds additional reactive current into the grid.</p> <p>P priority: Dynamic grid support active with effective power priority on account of immunity to interference and dynamic reactive current. The inverter feeds in as much effective power as possible. If, as a result of this, the maximum continuous current is not achieved, the inverter supplies additional reactive current.</p> <p>Zero current mode: Dynamic grid support active on account of immunity to interference and zero current feed-in. During a voltage incident, the current in the inverter is reduced to zero.</p>
		Reference voltage	<ul style="list-style-type: none"> ☞ Set reference voltage for active control process (nominal value of phase neutral conductor voltage for grid).
		K pos. sequence	<ul style="list-style-type: none"> ☞ Set amplification factor k in pos. sequence for dip and swell in grid voltage.
		K neg. sequence	<ul style="list-style-type: none"> ☞ Set amplification factor k in neg. sequence for dip and swell in grid voltage.
		Dead band	<ul style="list-style-type: none"> ☞ Set dead band in %. <p>NOTE: Dynamic grid support through dynamic reactive current in the case of voltage events with a voltage change greater than the dead band.</p>
		Voltage range	<ul style="list-style-type: none"> ☞ Set voltage range for the active control process. <p>NOTE: Dynamic grid support through dynamic reactive current is activated in the case of voltage events with voltages outside the normal voltage range and disabled when the voltage returns to the normal voltage range.</p>
		Dynamic reactive current only	<p>NOTE: With FRT mode activated, the pre-fault reactive current can be added.</p> <ul style="list-style-type: none"> ☞ If necessary, activate pre-fault reactive current.
		Dead band mode	<ul style="list-style-type: none"> ☞ Select dead band mode for the active control process. <p>NOTE: Mode 1: When calculating the reactive current, the value of the dead band is not subtracted from the amount of voltage change. In mode 2, the value of the dead band is subtracted from the amount of voltage change.</p>

Country-spec. setting	Menu level	Display/ setting	Action in this menu/meaning
All countries	1-2-3-4	Reactive power	<ul style="list-style-type: none"> ☞ Open the menu: Press the right arrow button or the Enter button. ☞ Activating reactive power process: select process and press Enter. The active process is highlighted.
	1-2-3-4	cos-phi const.	<ul style="list-style-type: none"> ☞ Determine the prescribed shift factor. ☞ If not equal to 1 is selected: Select the type of phase shift (under-excited (inductive load) /over-excited (capacitive load)).
	1-2-3-4	Q const.	<ul style="list-style-type: none"> ☞ Set the reactive power Q (as % of nominal power) to a fixed value. ☞ Select the type of phase shift (under-excited/over-excited).
All countries	1-2-3-4	cos-phi(P/Pn)	<ul style="list-style-type: none"> ☞ Open the menu: Press the right arrow button or the OK button.
	1-2-3-4	Lock-in voltage	<ul style="list-style-type: none"> ☞ Set voltage range at which the grid support process is active.
	1-2-3-4	Lock-out voltage	<ul style="list-style-type: none"> ☞ Set voltage range at which the grid support process is active.
	1-2-3-4	Number of nodes	<p>NOTE: The maximum number of configurable nodes depends on the selected grid type.</p> <ul style="list-style-type: none"> ☞ Specify the number of nodes for the reactive power characteristic curve.
	1-2-3-4	1st, ..., 10th node	<ul style="list-style-type: none"> ☞ Specify the power factor for the 1st , ... ,10th node. ☞ Set cos-phi of node. <p>NOTE: For the 1st node, the power must be 0%; for the last node, the power must be 100%. The power values of the nodes must increase continuously.</p> <ul style="list-style-type: none"> ☞ If a power factor not equal to 0 is selected: Select the type of phase shift (under-excited/over-excited).
All countries	1-2-3-4	Q(U) 10 nodes	<ul style="list-style-type: none"> ☞ Open the menu: Press the right arrow button or the Enter button.
	1-2-3-4	Lock-in power	<ul style="list-style-type: none"> ☞ Set the effective power as % of nominal power, in which the grid support process is active.
	1-2-3-4	Lock-out power	<ul style="list-style-type: none"> ☞ Set the effective power as % of nominal power, in which the grid support process is active.
	1-2-3-4	Lock-in time	<ul style="list-style-type: none"> ☞ Set period for grid observation (in seconds) for the active grid support process.
	1-2-3-4	Lock-out time	<ul style="list-style-type: none"> ☞ Set period for grid observation (in seconds) for the active grid support process.
	1-2-3-4	Transient time	<ul style="list-style-type: none"> ☞ Set the response speed of the control.
	1-2-3-4	Downtime	<ul style="list-style-type: none"> ☞ Set the intentional delay for the start of the Q(U) function
	1-2-3-4	Limitation of output gradient	<ul style="list-style-type: none"> ☞ Specify output gradient increase and decrease in ‰ - (per thousand) / minute.

Country-spec. setting	Menu level	Display/ setting	Action in this menu/meaning
	1-2-3-4	Minimum cos-phi Q1 and Q4	<p>NOTE: In the event of a significant voltage deviation, the maximum reactive power adjustment range can be limited by a minimum $\cos \varphi$ in order to prevent an excessive reactive power supply and, as a result, a significant reduction in the maximum effective power that can be fed in.</p> <p>☞ Enter the minimum cos-phi factor for quadrants 1 and 4.</p>
	1-2-3-4	Priority mode	<p>☞ Set priority for reactive power - Q or active power - P.</p> <p>NOTE: When it comes to P priority, the reactive power adjustment range is limited subject to the effective power that is currently available and fed in.</p>
	1-2-3-4	Active curve	<p>☞ Select the active curve for regulation.</p> <p>NOTE: Up to 4 characteristic curves can be configured independently and one of them can be activated for regulation each time.</p>
	1-2-3-4	Resetting the curve	☞ Reset active curve to the default setting.
All countries	1-2-3-4	Number of nodes	<p>NOTE: The maximum number of configurable nodes depends on the selected grid type.</p> <p>☞ Specify the number of nodes for the reactive power characteristic curve.</p>
	1-2-3-4	1st, ... ,10th node	<p>☞ Specify the reactive power in %S_{nom} for the 1st , ... ,10th node.</p> <p>NOTE: The voltage values of the nodes must increase continuously. For voltages below the 1st node and voltages above the last node, the reactive power value of the 1st or last node is used each time.</p> <p>☞ If a reactive power not equal to 1 is selected: Select the type of phase shift (under-excited (inductive load) /over-excited (capacitive load)).</p>
All countries	1-2-3-4	Extended standalone grid detection	<p>NOTE: Grid operators require shutdown of the inverter with standalone grid detection.</p> <p>☞ Open the menu: Press the right arrow button or the Enter button.</p>
	1-2-3-4	Operation mode	☞ Select the type of detection using the right arrow button.
	1-2-3-4	OFF	☞ Disables standalone grid recognition.
	1-2-3-4	ROCOF	☞ Activate passive grid influence by application of a frequency.
	1-2-3-4	Extended ROCOF	☞ Activate active grid influence by additional reactive power feed-in.
	1-2-3-4	Frequency shift	☞ Activate frequency shift.
	1-2-3-4	ROCOF threshold	☞ Specify threshold value for ROCOF (if ROCOF or Extended ROCOF is active).

Country-spec. setting	Menu level	Display/setting	Action in this menu/meaning
BE, CH-NS, CY, DE-NS, DK, JP, LU-NS, TW, UD		Line error	 Display of grid faults. To show the last 5 grid fault messages, select the "Show" key.
		"Information" menu	 Open the menu: Press the right arrow button or the OK button.
All countries		Inv. type	 Displays the type designation of the inverter. If feed-in power is actively limited: display maximum power in kW.
		SW version	 Displays the installed software version.
		Serial no.	 Displays the serial number of the inverter.
		Display country	 Displays the selected country setting. Optional: Displays the grid type if a grid type has been selected.
		"Manufacturer" menu	 The display shows information about the unit manufacturer.



NOTE

Please refer to the application note "APL_Software_Function_Description" on our website for more information about individual menu functions.

8.4 Inverter monitoring

The inverter has an integrated web server. This makes it possible to monitor and record the operating state and yield of your PV system.

You can display the recorded data using:

- The integrated LCD
- The integrated web server using an Internet-capable device connected to the Ethernet interface of the inverter
- A storage medium connected to the USB interface, for example, a USB stick.

8.4.1 USB interface

Use an external USB storage device to read operating data saved in the inverter.

Reading log data



NOTE

The USB interface is approved solely for use with USB flash storage devices ("USB sticks"). The maximum available current is 100 mA. If a device with a higher power requirement is used, the power supply for the USB interface automatically shuts down to protect the inverter from damage.

Reading data

1. Connect a suitable USB storage device to the USB interface on the communication circuit board.
2. Open the "Log data display" menu.
3. Select the "Save to USB" item.
4. Select the desired log data using the 4-way button.
5. Press the Enter button.

» The inverter saves the selected log data to the USB storage device.

8.4.2 Web server

The inverter has an integrated web server. After configuring the network and activating the web server in the Settings menu, you can open the web server from an Internet browser. The language version of the website delivered by the web server is adapted dynamically to the pre-set language preferences in your Internet browser. If your Internet browser requests a language that is unknown to the inverter, the web server uses the menu language set in the inverter.

Setting up the web server

Configuring the Ethernet interface

- ☪ You have connected the inverter to your network.
 - ☞ When using a DHCP server: Activate DHCP.
 - ☞ For manual configuration (DHCP off):
1. Open the Settings/Network menu.
 2. Assign a unique IP address.
 3. Assign a subnet mask.
 4. Assign a gateway.
 5. Assign DNS server.
 6. Save your settings.

Using the web server

To avoid problems with incompatibility, use the most recent version of your Internet browser. JavaScript must be enabled in the browser settings to display the web server correctly.



NOTE

You can also access the web server of the inverter via the Internet. To do this, additional settings of your network configuration, particularly your Internet router, are required. Note that communication with the inverter is carried out over an unsecured connection, particularly in the case of a connection over the Internet.

Calling up the web server

- ☪ Configure the Ethernet interface.
 - ☪ Connect the Ethernet cable.
1. Open an Internet browser.
 2. In the address field of the Internet browser, enter the IP address of the inverter and open the site.
- » The Internet browser displays the start screen of the web server.

After it has opened, the web server displays information about the inverter as well as the current yield data. The web server enables the following measurement data and yield data to be displayed:

- | | |
|-----------------|---------------------|
| • Feed-in power | • Generator power |
| • Status | • Generator voltage |
| • Grid power | • Unit temperature |
| • Grid voltage | |

In order to display and export yield data, proceed as follows:

Select the display period

1. Open the web server.
2. Select the display period by choosing either daily view, monthly view, yearly view or overview.

Filtering display data (daily view only)

1. Open the web server.
2. Select daily view.
3. To show or hide measurements, select or deselect the corresponding checkboxes in the "Choose view" area.

Exporting data

1. Filter the display data if necessary.
2. Select the display period if applicable (daily, monthly, yearly or overview).
3. Press the "Export data" button.
4. Save the file.



NOTE

Regardless of the display data selected in the "Choose view" area, an export file always contains all measurement data and yield data available for the selected period

8.5 Performing the software update

You can update the software of the inverter to a new version using the integrated USB interface. Use a FAT32-formatted USB stick to do this. Do not use any storage media with an external power supply such as an external hard disk.



NOTE

Ensure that the AC and DC inverter power supply is active. It is only possible to update all of the inverter's components to the most current software version in this operating state.

CAUTION

Damage to the inverter

The update can fail if the power supply is interrupted during the update process. Parts of the software or of the inverter itself can then be damaged.

- » Never disconnect the DC and AC power supply during a software update.
- » Do not remove the USB stick during a software update.

Preparing for the software update

1. Download the software update file from the KACO web site and store it on your hard disk.
2. Copy the update file (.KUF) onto the USB stick.
- » Perform software update.



NOTE

The update can take several minutes. The "Operating" LED flashes during the update process. The inverter may restart several times.

The following message appears if the DC power supply is too low: "DC power supply too low! Perform update anyway?"

In this case, select "No" and perform the update with a stable voltage supply.

Performing the software update

- ↻ Prepare for the software update.
- 1. Connect the USB stick to the inverter.
- » The message "Software found. Would you like to load it?" appears on the display.

2. If you would like to perform the update, select the "Yes" button. In the case of "No", pressing the "Enter" key stops the update process and the unit goes into feed-in mode.
 - » The inverter begins the update.
 - The update has been imported in full once the message "Software update successful" appears.
 - If the update has failed, the message "Software update incomplete" appears.
3. When a fault occurs, the update process must be repeated.

Alternatively, you can check to see if the update was successful in the menu:

Displaying the software version

- ☞ Open the Information / SW version menu.
- » The inverter will display the versions and checksums of the software that is currently loaded.

9 Maintenance/Troubleshooting

9.1 Visual inspection

Inspect the inverter and the cables for exterior visible damage and note the operating status display of the inverter. In case of damage, notify your installer. Repairs may only be carried out by authorised electricians.



NOTE

There are components in the housing of the inverter which may only be repaired by our KACO customer service team.

The inverter should be checked for proper operation by a qualified electrician at regular intervals and if you experience problems, you should always contact our customer service team..

9.2 Cleaning the housing



DANGER



Lethal voltages in the inverter!

Serious injuries or death can result if moisture enters the system.

- › Only use completely dry objects to clean the inverter.
- › The inverter should only be cleaned from the outside.

Cleaning the inverter

- ☞ Do not use compressed air!
- ☞ Use a vacuum cleaner or a soft brush to remove dust from the fan cover and from the top of the inverter on a regular basis.
- ☞ Remove dust from the ventilation inlets if necessary.

9.3 Replacing or cleaning the fans

2 fans are located on the underside of the unit. These fans must be replaced if they break down or become very dirty.

Dismount the fan

- ⊖ Ensure complete disconnection on the AC and DC sides.
- 1. Wait until both fans are no longer turning.
- 2. Dismount the fastening on the fan's protective grating with a T20 screwdriver and an SW7 spanner.
- 3. Dismount the fastening for the fan with a T20 screwdriver and take the fan down carefully.
- 4. Carefully disconnect the plug connector for the dismantled fan from inside the housing (see Figure 44).
- 5. Remove the fan from the base plate.
- » Install the replacement fan.

Installing the replacement fan

- ⊖ You have removed the defective fan.
 - ⊖ Replace the fan only with a fan recommended by KACO new energy. If necessary, contact KACO service!
- Note:** Make sure that the fan is positioned correctly when installing!
6. Insert the connection plug into the corresponding socket inside the housing.
 1. Insert the replacement fan into the base plate (see Figure 16).
 2. Mount the fastening for the fan onto the base plate with a T20 screwdriver with a tightening torque of 2.5 Nm.
 3. Mount the fastening for the fan's protective grating with a T20 screwdriver and an SW7 spanner.
 4. If required, fit another fan.
 5. Switch on the inverter as described in section 7.10 on page 30 onwards.

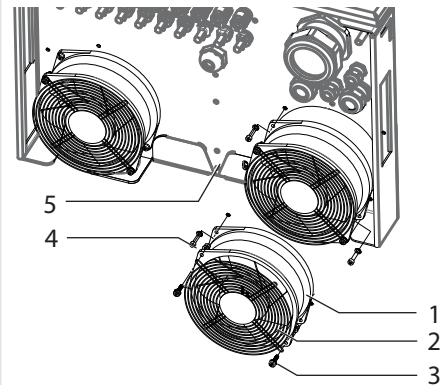

Figure 43: Dismount the fan

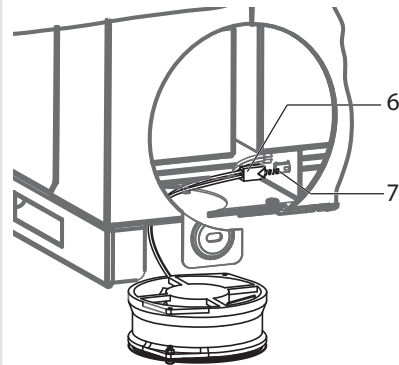

Figure 44: Disconnect the fan's plug

Key

1	Fan
2	Protective grating for fan
3	Fastening for protective grating
4	Fastening for fan
5	Base plate
6	Connection plug
7	Connection socket

9.4 Servicing the heat sinks

CAUTION



Risk of burns from hot surface.

Heat sinks become very hot when in operation!

- › Never touch the heat sinks after operation.
- › Allow the heat sinks at least 10 minutes to cool down before cleaning.

Cleaning the heat sink

- ⊖ If the heat sink is heavily soiled, we recommend that you dismount the fans temporarily.
- ⊖ Switch off the unit and secure it against restart.
- ⊖ Have an appropriate brush to hand (25x4mm) to clean the heat sink.

1. Clean off any adhering dust and dirt particles from the heat sink's protective plate.
2. Detach the fastening for the heat sink's protective plate with a T20 screwdriver.
3. Remove the screws and the lock washer.
4. Clean the heat sink with a suitable brush.

NOTE: Do not use any aggressive cleaning agents and ensure that no other components come into contact with fluids.

» Cleaning completed - if necessary, remount the fans.

Fitting the heat sink's protective plate

- ⌚ Thorough cleaning is completed.
- 1. Fit the heat sink's protective plate.
- 2. Attach the fastening for the heat sink's protective plate with a T20 screwdriver.
- » The heat sink has now been serviced.

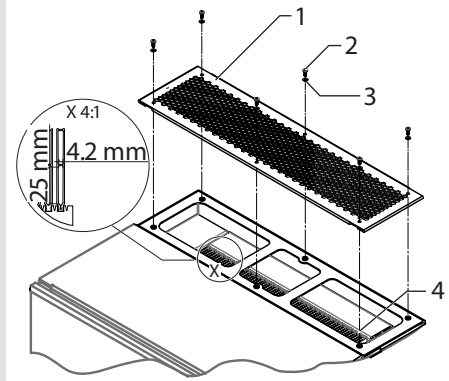

Figure 45: Cleaning the heat sink

Key

1	Heat sink's protective plate
2	Fastening for protective plate
3	Lock washer
4	Heat sink

9.5 Shutting down for maintenance and troubleshooting

 **DANGER**

Lethal voltages are still present in the terminals and cables of the unit even after the unit has been switched off and disconnected.

Severe injuries or death will occur when touching the cables and terminals in the inverter.

Only appropriately qualified and authorised electricians may open and maintain the inverter.



- › Observe all safety regulations and the current technical connection specifications from the relevant power supply company.
- › Switch off the grid voltage by turning off the external circuit breakers.
- › Disconnect the DC side depending on the device version:
 - XL device version: Switch off the DC supply using the DC isolator switch.
 - Device version Basic + M: Switch off DC power supply externally via a combiner box (not supplied).

DANGER! The DC cables are still live!

- › After shutdown, wait at least five minutes before opening the inverter.

 **DANGER**

Risk of fire if the fuse holder is disconnected in a live state.

The connection terminals and fuse holder can be destroyed by arcing if disconnected or if the fuses are removed.



1. Switch off the grid voltage by turning off the external circuit breakers.
2. Switch off the PV generator using the DC isolator switch.

DANGER! The DC cables are still live!

3. Check that there is no current in any of the DC cables using a clip-on ammeter.
4. Only open the fuse holder once you have established that there is no current in the DC cables.
5. Ensure that there is no voltage present on the grid connection terminals.

9.6 Disconnecting connections

9.6.1 Disconnecting the AC connection

DANGER

Risk of fatal injury due to electric shock!



Never disconnect the connection plug and plug connector under load.

- › Switch off the grid voltage by turning off the external circuit breakers before you detach the AC cables from the screw terminal.
- › Make sure that the device is isolated from the public power supply and the system power supply before starting work.

Disconnecting the AC connection

- ⊖ Ensure there is no AC/DC voltage present.
- 1. Open the housing and secure the door with the latch lever.
- 2. Detach cables (L1/L2/L3/N/PEN) from the AC connection terminal.
- 3. Detach the PE line from the earthing bolt.
- 4. Loosen the cable fitting and pull the cables out through the cable fitting.

9.6.2 Disconnecting the DC connection

DANGER

Destruction of the DC plug connectors



DC plug connectors can be destroyed by arcing if disconnected while still live. It is absolutely essential that the following shutdown sequence be carried out in the correct order:

1. Check that there is no current in any of the DC cables using a clip-on ammeter.
2. Only open the fuse holder once you have established that there is no current in the DC cables.
3. XL device version: Disconnect all DC connections one by one.
Device version Basic and M: Detach DC connection in the device.

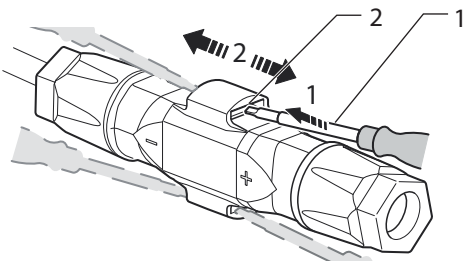

Figure 46: Disconnect plug connector (XL version)

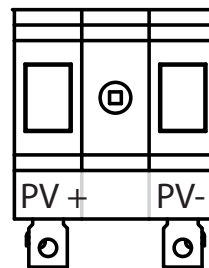

Figure 47: Disconnecting the PV cables (Basic + M version)

Key

- | | | | |
|---|-------------|---|-------|
| 1 | Screwdriver | 2 | Latch |
|---|-------------|---|-------|

Disconnecting the DC connector (XL version)

- ⊖ Check that there is no current using a clip-on ammeter.
- 1. Use a screwdriver (blade width 3 mm) to push down the latch on the coupling.
- 2. Leave the screwdriver in place.
- 3. Disconnect the DC connector from the DC socket.

Disconnecting the DC connection (Basic + M version)

- ⌚ Check that there is no current using a clip-on ammeter.
- 4. Remove the protection against contact from the PV+ and PV- terminal.
 1. Detach the DC cables from the PV+ and PV- terminals on the DC switch (see Figure 47 on page 52).
 2. Loosen the cable fitting and pull the PV cable through the cable fitting.
 3. Mounting the protection against contact on the PV+ and PV- terminal.
 4. Furnish the DC cable ends with protective caps.

9.7 Faults

9.7.1 Procedure



DANGER

Lethal voltages are still present in the terminals and cables of the inverter even after the inverter has been switched off and disconnected!

Severe injuries or death will occur when touching the cables and terminals in the inverter.

- ☞ When a fault occurs, notify an appropriately authorised and qualified electrician or KACO new energy GmbH Service.
- ☞ The operator can only carry out actions marked with a B.

- ☞ In case of power failure, wait for the system to automatically restart.
- ☞ Notify your electrician if there is an extended power failure.

9.7.2 Rectifying a fault

**B = Operator’s responsibility ; E = The indicated work may only be carried out by an authorised electrician.
K = The indicated work may only be carried out by a service employee of KACO new energy GmbH!**

Fault	Possible cause	Explanation/remedy	By
The display is blank and the LEDs do not light up	Grid voltage not available	☞ Check whether the DC and AC voltages are within the permitted limits (see Technical Data).	E
		☞ Notify KACO Service.	E
The inverter stops feeding into the grid shortly after being switched on, even though there is sunlight present.	Faulty grid separation relay in the inverter.	If the grid separation relay is defective, the inverter will recognise this during the self-test.	
		☞ Ensure that there is sufficient PV generator power.	E
		☞ If the grid separation relay is defective, have it replaced by KACO Service.	E
		☞ Notify KACO Service.	
The inverter is active but is not feeding into the grid. The display indicates a line failure.	Grid-feed is interrupted due to a grid fault.	Due to a grid fault (grid impedance too high, over/undervoltage, over/underfrequency), the inverter stopped the feed-in process and disconnected from the grid for safety reasons.	
		☞ Change the grid parameters within the permitted operating limits (see the “Start-Up” section).	E

Table 7: Troubleshooting

Fault	Possible cause	Explanation/remedy	By
The grid fuse trips.	The grid fuse capacity is too low.	In case of a high level of solar radiation, the inverter exceeds its rated current for a short period, depending on the PV generator.	
		☞ Select the capacity of the inverter's backup fuse to be somewhat higher than the maximum feed-in current (see the "Installation" section).	E
	☞ Contact the grid operator if the grid failure continues to occur.	E	
	Damage to the inverter's hardware.	If the grid fuse trips immediately when the inverter goes into feed-in mode (after the start-up period is complete), the inverter's hardware is probably damaged.	
		☞ Contact KACO Service to test the hardware.	E
The inverter displays an impossible daily peak value.	Faults in the grid.	The inverter continues to operate as normal without losses to the yield, even when an erroneous daily peak value is displayed. The value is reset overnight.	
		☞ To reset the value immediately, switch the inverter off by disconnecting it from the grid and switching off the DC, then switch it back on.	E
Daily yields do not correspond to the yields on the feed-in meter.	Tolerances of the measuring elements in the inverter.	The measuring elements of the inverter have been selected to ensure maximum yields. Due to these tolerances, the daily yields shown may deviate from the values on the feed-in meter by up to 15%.	
		☞ No action	-
The inverter is active but is not feeding into the grid. Display "Waiting for feed-in"	<ul style="list-style-type: none"> • Generator voltage too low • Grid voltage or PV generator voltage unstable. 	<ul style="list-style-type: none"> • The PV generator voltage or power is not sufficient for feed-in (solar radiation is too low). • The inverter checks the grid parameters before the feed-in process begins. The length of time it takes to switch back on again differs from country to country, depending on applicable standards and regulations, and may be several minutes. • The starting voltage may have been set incorrectly. 	
		☞ Adjust starting voltage in the Parameter menu if required.	K

Table 7: Troubleshooting









Fault	Possible cause	Explanation/remedy	By
Noise emission from the inverter.	Particular ambient conditions.	<p>When there are certain ambient conditions, the units may emit audible noises.</p> <ul style="list-style-type: none"> • Grid interference or grid failure caused by particular loads (motors, machines, etc.) which are either connected to the same point on the grid or located in the vicinity of the inverter. • In cases of volatile weather conditions (frequent switching between sunny and cloudy conditions) or strong solar radiation, a light hum may be audible due to the increased power. • Under particular grid conditions, resonances may form between the unit's input filter and the grid; these may be audible even when the inverter is switched off. <p>These noise emissions do not affect the operation of the inverter. They do not lead to loss of performance, failure, damage or to a shortening of the unit's service life.</p> <p>People with very sensitive hearing (particularly children) are able to hear the high-frequency hum caused by the inverter's operating frequency of approximately 17 kHz.</p> <p> No action</p>	
In spite of high radiation levels, the inverter does not feed the maximum power into the grid.	The device is too hot and the system limits the power.	<p>Because the temperatures inside the unit are too high, the inverter reduces its power to prevent damage to the unit. Note the technical data. Ensure that the convection cooling is not impeded from the exterior. Do not cover the cooling fins.</p> <p> Ensure sufficient cooling of the unit. B</p> <p> Remove any foreign bodies which are present on the unit. B</p> <p> Clean the cooling fins. E</p>	

Table 7: Troubleshooting

9.8 “Fault” messages on the display/LED

Many fault signals indicate a fault in the grid. They are not operational faults of the inverter. The triggering levels are defined in standards, e.g. VDE0126-1-1. The inverter shuts down if the values exceed or fall below the approved levels.

9.8.1 Display of status and fault messages

Display	Fault LED (red)		
FS (fault status)	 	ON	<ul style="list-style-type: none"> • Fault signal relay has switched. • Feed-in was ended due to a fault.
OS (operating status)	 	OFF	<ul style="list-style-type: none"> • The fault signal relay releases again. • The inverter feeds back into the grid again after a country-specific time period.

Details regarding the fault or operating status can be found either on the display or in the data that was recorded through the RS485 interface.

9.8.2 Status and fault signals

The following table lists the possible status and fault signals that the inverter shows on the LCD and the LEDs.

BS = operating status, FS = fault status;

B = Action of the operator

E = The indicated work may only be carried out by an authorised electrician!

K = The indicated work may only be carried out by a service employee of KACO new energy GmbH!

































Status	Display			Explanation	Action	
OS 1	Waiting for feed-in			Self-test: The grid parameters and generator voltage are being checked.	-	-
OS 2	Generator voltage too low			Insufficient generator voltage and power, status before the transition to night shutdown	-	-
OS 8	Self-test			Checks the shutdown of the power electronics as well as the grid relay before feed-in mode.	-	-
FS 10	Temperature in unit too high			In case of overheating, the inverter switches off. Possible causes: <ul style="list-style-type: none"> Excessively high ambient temperature, Fan covered, Inverter defective. 	 Cool off the area around the inverter.  Uncover the fans.  Notify your authorised electrician!	B B E
OS 11	Measured values			Power limitation: If the generator power is too high, the inverter limits itself to the maximum power (e.g. around noon if the generator capacity is too large).	-	-
FS 17	Shutting down Powador-protect			The activated grid and system protection has been tripped.	 Wait for reactivation.  Notify your authorised electrician if the fault occurs repeatedly!	E
FS 18	Resid. current shutdown			Residual current was detected. The feed-in was interrupted.	 Notify your authorised electrician!	E
FS 19	Insulation fault generator			There is an insulation fault on the PV generator. The feed-in was interrupted.	 Notify your authorised electrician if the fault occurs repeatedly!	E
FS 30	Fault Transformer fault			The current and voltage measurements in the inverter are not within acceptable range.	-	-
FS 32	Fault Self-test			The internal grid separation relay test has failed.	 Notify your authorised electrician if the fault occurs repeatedly!	E
FS 33	Fault DC feed-in			The DC feed-in has exceeded the permitted value. This DC feed-in can be caused by grid conditions and may not necessarily indicate a fault.	 Notify your authorised electrician if the fault occurs several times.	E

Table 8: Operating status and fault messages on the display









































Status	Display			Explanation	Action	
FS 34	Internal communication error			A communication error has occurred in the internal data transmission.	<ul style="list-style-type: none">  Notify your authorised electrician.  Check the data cable. 	E
FS 35	Protection shutdown SW			Protective shutdown of the software (AC overvoltage, AC overcurrent, DC link overvoltage, DC overvoltage, DC overtemperature).	Not a fault! Grid-related shutdown, the grid connects again automatically.	
FS 36	Protection shutdown HW			Protective shutdown of the hardware (AC overvoltage, AC overcurrent, DC link overvoltage).	Not a fault! Grid-related shutdown, the grid connects again automatically.	
FS 38	Generator overvoltage error			The voltage of the PV generator is too high. The PV generator is configured incorrectly.	<ul style="list-style-type: none">  Notify your authorised electrician! 	E
FS 41-46	Line failure: Undervoltage L1/L2/L3 Overvoltage L1/L2/L3			The voltage of a grid phase is too low; the grid cannot be fed into. The phase experiencing failure is displayed.	<ul style="list-style-type: none">  Notify your authorised electrician! 	E
FS 47	Grid failure phase-to-phase voltage			The measured phase-to-phase voltage is outside of the tolerance limits.	<ul style="list-style-type: none">  Check software version (possible crash during upload)  Notify KACO Service! 	B/K
FS 48	Line failure Underfrequency			Grid frequency is too low. This fault may be grid-related.	<ul style="list-style-type: none">  Notify your authorised electrician! 	E
FS 49	Line failure Overfrequency			Grid frequency is too high. This fault may be grid-related.	<ul style="list-style-type: none">  Notify your authorised electrician! 	E
FS 50	Line failure Average voltage			The grid voltage measurement according to EN 50160 has exceeded the maximum permitted limit value. This fault may be grid-related.	<ul style="list-style-type: none">  Notify your authorised electrician! 	E
FS 57	Waiting for reconnect			Waiting time of the inverter after a fault.	Inverter does not switch on again until the country-specific time has elapsed.	
FS 58	Overtemperature Control card			The temperature inside the unit was too high. The inverter switches off to prevent damage to the hardware.	<ul style="list-style-type: none">  Provide for sufficient ventilation. 	E
FS 59	Self test error			A fault occurred during a self-test.	<ul style="list-style-type: none">  Notify your authorised electrician. 	E
OS 60	Generator voltage too high			The inverter does not begin feeding into the grid until the PV voltage falls below a specified value.	-	-
OS 61	External limit (%)			The external limit <i>Power control</i> was activated by the grid operator. The inverter limits its power.		

Table 8: Operating status and fault messages on the display







































Status	Display	 	Explanation	Action	
OS 63	Measured values	 	P(f)/frequency-dependent power reduction: Frequency-dependent power reduction will be activated when the BDEW (German Association of Energy and Water Industries) Medium Voltage Directive goes into effect. Power reduction starts at a frequency of 50.2 Hz.		
OS 64	Measured values	 	Output current limiting: The AC current is limited once the specified maximum value has been reached.		
FS 67	Fault at power section 1	 	There is a fault in the power section.	 Notify your authorised electrician.	E
FS 70	Fan error	 	The fan is malfunctioning.	 Replace defective fan.	E
FS 73	Standalone grid err.	 	Standalone mode was detected.	-	-
OS 74	External idle power requirement	 	The grid operator limits the feed-in power of the inverter via the transmitted reactive power factor.	-	-
OS 79	Insulation measurement	 	PV generator's insulation is being measured	-	-
FS 80	Insulation meas. not possible	 	The insulation measurement cannot be performed because the generator voltage is too volatile.	-	-
FS 81, 82, 83	Protection shutdown line volt. L1 L2, L3	 	Overvoltage has been detected on a conductor. An internal protective mechanism has disconnected the device to protect it against damage.	 In case of repeated occurrence: Notify your authorised electrician!	E
FS 84	Protection shutdown undervolt. DC link	 	A voltage deviation has been found in the DC link. An internal protective mechanism has disconnected the device to protect it against damage.	 In case of repeated occurrence: Notify your authorised electrician!	E
FS 85	Protect. shutdown overvolt. DC link	 	In a TN-C-S grid, the PE must be connected to the device and at the same time the PEN bridge in the inverter must be removed.	 In case of repeated occurrence: Notify your authorised electrician!	E
FS 86	Protection shutdown: DC link asymmetry	 	Overvoltage has been found in the DC link. An internal protective mechanism has disconnected the device to protect it against damage.	 In case of repeated occurrence: Notify your authorised electrician!	E
FS 87, 88, 89	Protection shutdown overcurrent L1, L2, L3	 	A current that has been found on a conductor is too high. An internal protective mechanism has disconnected the device to protect it against damage.	 In case of repeated occurrence: Notify your authorised electrician!	E
FS 93, 94	Self test error Buffer 1, Buffer 2	 	The control board is defective.	 Notify authorised electrician / KACO Service!	E/K

Table 8: Operating status and fault messages on the display























Status	Display	 	Explanation	Action	
FS 95, 96	Self test error Relay 1, Relay 2	 	The power section is defective.	 Notify KACO Service	K
FS 97	Protection shutdown overcurrent HW	 	Too much power has been fed into the grid. Complete disconnection of the device.	 Notify authorised electrician / KACO Service!	E/K
FS 98, 99	Protection shutdown HW gate driver/ HW buffer-free.	 	An internal protective mechanism has disconnected the device to protect it against damage. Complete disconnection of the device.	 Notify authorised electrician / KACO Service!	E/K
FS 100	Protect. shutdown HW overheating	 	The device has been switched off because the temperatures in the housing were too high.	 Check to make sure that the fans are working.  Replace fan if necessary.	B E
FS 101, 106	Temperature plausibility error, efficiency, DC link, AFI module, relay, DC/DC converter	 	The unit has shut down because of implausible internal measured values.	 Notify KACO Service!	K
FS 107	Check surge protection device	 	Surge protection device (if present in the device) has tripped and must be reset if appropriate.	 Check functional display of surge protection device.  Observe application note on the KACO website: Installing a surge protection device.	K

Table 8: Operating status and fault messages on the display

10 Service

If you need help solving a technical problem with one of our KACO products, please contact our service hotline.

Please have the following information ready so that we can help you quickly and efficiently:

- Device name / serial number
 - Date of installation / Start-up report
 - Fault message shown on the display / Description of the fault / Did you notice anything unusual? / What has already been done to analyse the fault?
 - Module type and string circuit
 - Consignment identification / Delivery address / Contact person (with telephone number)
 - Information about the accessibility of the installation site.
- Any additional costs arising from unfavourable structural or mounting conditions shall be billed to the customer.

You can find the following items and other information at our web site <http://www.kaco-newenergy.com/>:

- our current warranty conditions,
- a complaint form,
- the option for registering your device with us. In this manner, you can assist us in providing you with the quickest service possible.

Note: The maximum length of the warranty is based on the currently applicable national warranty conditions.

Service hotline	Technical troubleshooting	Technical consultation
Inverter	+49 (0) 7132/3818-660	+49 (0) 7132/3818-670
Data logging and accessories	+49 (0) 7132/3818-680	+49 (0) 7132/3818-690
Customer Service	Monday to Friday 08:00 a.m. to 12:00 p.m. (CET) and 01:00 p.m. to 5:00 p.m.	

11 Shutdown/Disassembly

11.1 Switching off the unit

DANGER

Lethal voltages are still present in the terminals and cables of the inverter even after the inverter has been switched off and disconnected!

Severe injuries or death will occur when touching the cables and terminals in the inverter.

- › Only appropriately qualified and authorised electricians may open and uninstall the inverter.
- › Observe all safety regulations and the current technical connection specifications from the relevant power supply company.



1. Switch off the grid voltage by turning off the external circuit breakers.
2. Disconnect the DC side depending on the device version:
 - XL device version: Switch off the DC supply using the DC isolator switch.
 - Device version Basic + M: Switch off DC power supply externally via a combiner box (not supplied).
3. Check that there is no current in any of the DC cables using a clip-on ammeter.
4. Only open the fuse holder once you have established that there is no current in the DC cables.
5. Secure the inverter against reconnection.

DANGER

Destruction of the DC plug connectors

DC plug connectors can be destroyed by arcing if disconnected while still live. It is absolutely essential that the following shutdown sequence be carried out in the correct order:



1. Check that there is no current in any of the DC cables using a clip-on ammeter.
2. Only open the fuse holder once you have established that there is no current in the DC cables.
3. XL device version: Disconnect all DC connections one by one.
Device version Basic and M: Detach DC connection in the device.

CAUTION

Risk of burns from hot housing components!

Coming into contact with the housing can cause burns.



- › Do not touch the housing surface or heat sink during and immediately after operation.
- › Allow the device to cool down before touching the housing surface.

11.2 Uninstalling the device

⊖ Inverter disconnected and secured against restart.

1. Unlock and open the housing door.
 2. Remove the interface cables.
 3. Detach AC cables from the connection terminals (see chapter 9.6 on page 52).
 4. DC cables
 - Basic + M version: detach from the connection terminals and furnish with protective caps.
 - XL version: detach from the DC plug connectors and furnish with protective caps.
- » The inverter is uninstalled. Proceed with disassembly.

11.3 Disassembling the unit

- ⌚ Unit has been switched off and uninstalled.
- 1. Remove the unit from the wall holder in the opposite order to the assembly instructions (see section 6.3 on page 16).
- 2. Securely pack up the unit if it is to be used later, or have the unit disposed of in the correct manner.

11.4 Packaging the unit

- ⌚ The inverter is uninstalled.
- 1. If possible, always pack the inverter in the original packaging. If this is no longer available, an alternative is to use equivalent packaging.
- 2. You must be able to close the box completely and it must be able to accommodate the weight and size of the inverter.

11.5 Storing the unit

- ⌚ The inverter is packed.
- 📦 Store the inverter in a dry place, in accordance with the ambient temperature range (see chapter 4.2 on page 11).

12 Disposal

CAUTION



Risk to the environment if disposal is not carried out in the correct manner

For the most part, both the inverter and the corresponding transport packaging are made from recyclable raw materials.

Unit: Do not dispose of faulty inverters or accessories together with household waste. Ensure that the old unit and any accessories are disposed of in a proper manner.

Packaging: Ensure that the transport packaging is disposed of properly.

13 Appendix

13.1 EU Declaration of Conformity

Manufacturer's name and address	KACO new energy GmbH Carl-Zeiss-Straße 1 74172 Neckarsulm, Germany
Product description	Photovoltaic feed-in inverter
Type designation	KACO blueplanet 50.0 TL3 M1 WM OD IIGM KACO blueplanet 50.0 TL3 M1 WM OD IIGB KACO blueplanet 50.0 TL3 M1 WM OD IIGX KACO blueplanet 50.0 TL3 M1 WM OD FRGX

This is to confirm that the units listed above comply with the protection requirements set forth in the Directive of the Council of the European Union of 26th February 2014 on the harmonisation of the laws of the member states relating to Electromagnetic Compatibility (2014/30/EU) and the Low Voltage Directive (2014/35/EU).

The units conform to the following standards:

2014/35/EU

"Directive relating to electrical equipment designed for use within certain voltage limits"

2014/30/EU

"Directive relating to electromagnetic compatibility"

Safety of the unit

EN 62109-1:2010

EN 62109-2:2011

Interference immunity

EN 61000-6-1:2007

EN 61000-6-2:2005+ AC:2005

Emitted interference

EN 61000-6-3:2007 + A1:2011+ AC:2012

Secondary effects on the grid

EN 61000-3-11:2000

EN 61000-3-12:2011

The types mentioned above are therefore labelled with the CE mark.

Unauthorised modifications to the supplied units and/or any use of the units that is contrary to their intended use render this Declaration of Conformity null and void.

Neckarsulm, 08.09.2017
KACO new energy GmbH



p.p. Matthias Haag
Management team for technology / CTO

